



# AEROBARRIER- SELECT OPERATIONS MANUAL





2024

---

**AEROBARRIER SELECT  
ENVELOPE SEALING  
OPERATIONS MANUAL**

# TABLE OF CONTENTS



1. AIRFLOW BASICS / ENVELOPE LEAKAGE
2. SCOPE OF WORK
3. SEALING / SET UPS
4. EQUIPMENT
5. AEROSUITE SOFTWARE
6. MAINTENANCE
7. APPENDIX

# “MAKE IT TIGHT VENTILATE RIGHT”

## HOMES LEAK AIR

- INFILTRATION
- EXFILTRATION

**UNCONTROLLED AIR FLOWS,  
DEFEAT COMFORT AND IAQ**

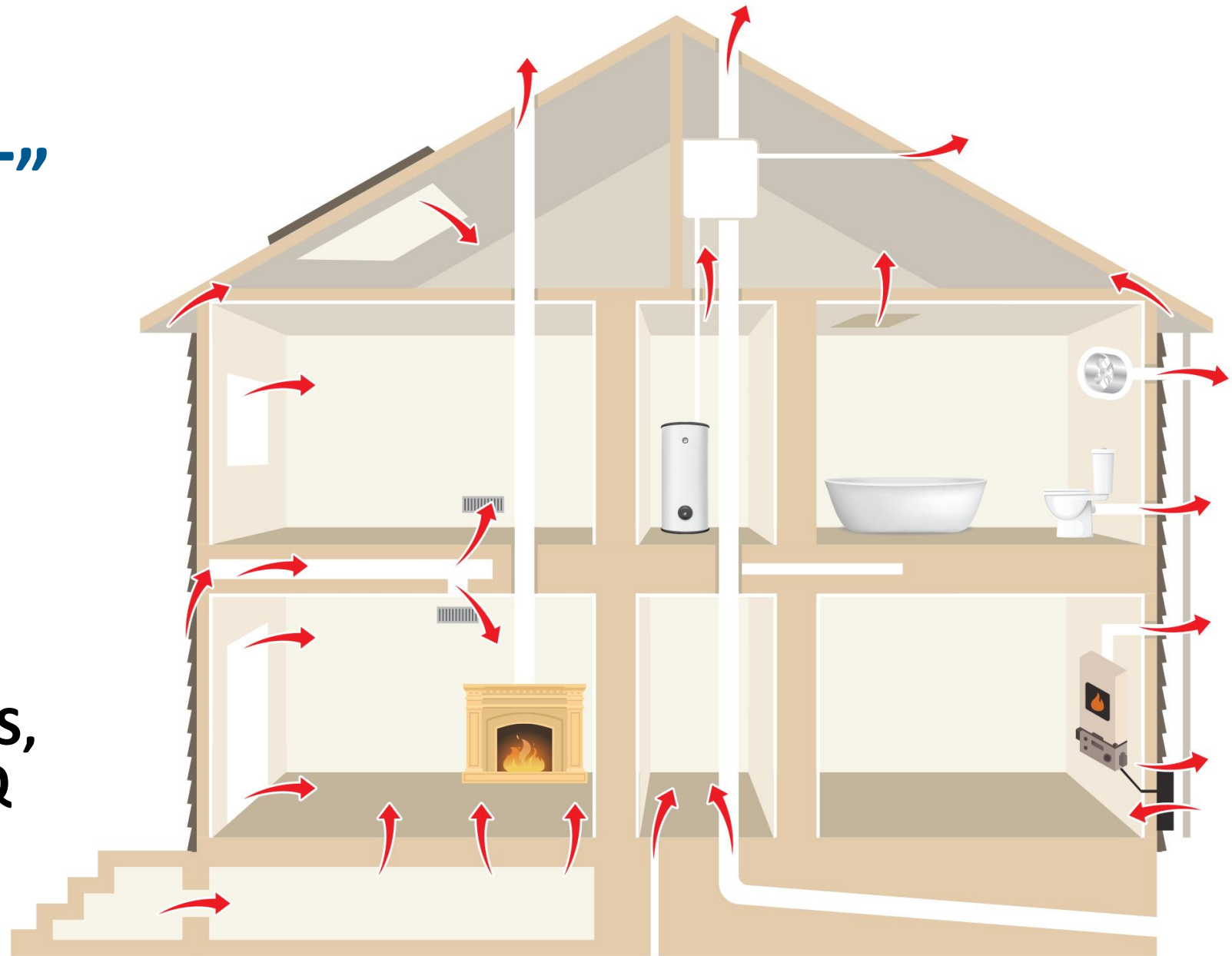



## Air Sealing Trouble Spots



- 1 Air Barrier and Thermal Barrier Alignment
- 2 Attic Air Sealing
- 3 Attic Kneewalls
- 4 Shaft for Piping or Ducts
- 5 Dropped Ceiling/Soffit
- 6 Staircase Framing at Exterior Wall
- 7 Porch Roof
- 8 Flue or Chimney Shaft
- 9 Attic Access
- 10 Recessed Lighting
- 11 Ducts
- 12 Whole-House Fan
- 13 Exterior Wall Penetrations
- 14 Fireplace Wall
- 15 Garage/Living Space Walls
- 16 Cantilevered Floor
- 17 Rim Joists, Sill Plate, Foundation, Floor
- 18 Windows & Doors
- 19 Garage/Living Space Walls

# “MAKE IT TIGHT VENTILATE RIGHT”

## HOMES LEAK AIR

- INFILTRATION
- EXFILTRATION

**UNCONTROLLED AIR FLOWS,  
DEFEAT COMFORT AND IAQ**

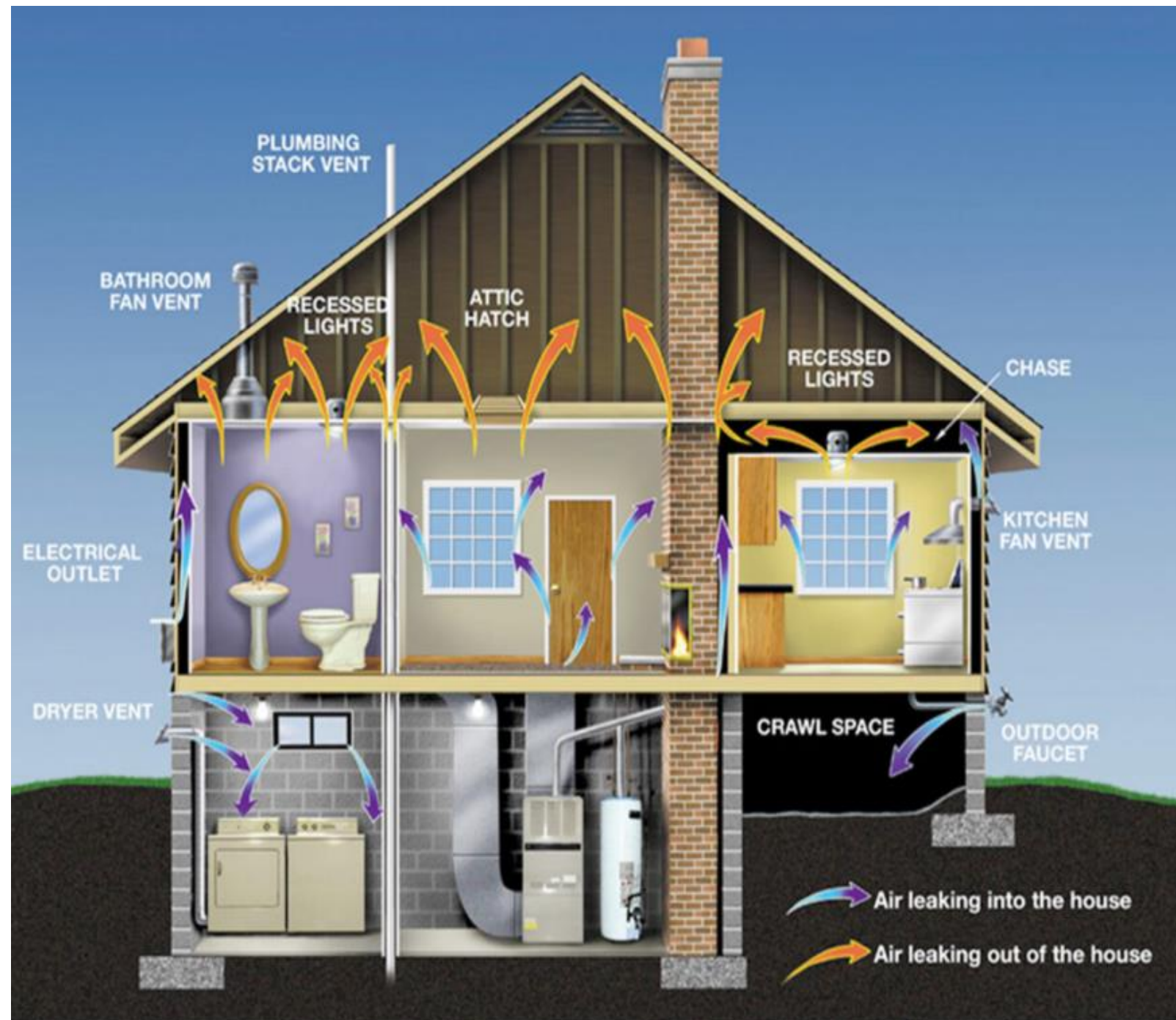

# Types of Leakage in a Building Envelope

- Top & Bottom Plates
- Drywall leaks
- Stud leakage
- Boot leakage





# Top & Bottom Plates

- These leaks are found as gaps between the drywall and ceiling/subflooring



Video of this process



# Stud Penetrations

- Behind the drywall, these gaps are sealed by the sealing process



# Drywall Penetrations to be sealed



The gaps in the drywall around:

- Electrical Wires
- Lighting fixtures
- Outlets
- Plumbing
- Dryer vent
- Windows and Doors
- Bathroom / Kitchen Exhaust
- Audio equipment/speakers

\*Sealant can travel past the interior gaps and seal leaks beyond



# Efficiency Demands Are Higher



Air-sealing requirements for new construction is becoming increasingly more difficult. Many states throughout the US have already adopted the 2018 International Energy Conservation Code (IECC) requirement of 3 ACH<sub>50</sub> and more states and municipalities will follow. **You need to prepare now.**

Air sealing with the Aeroseal Envelope process can help you meet or exceed the 2018 IECC requirements every time, guaranteed. AeroBarrier reduces outside air infiltration up to 70%



**2009 IECC Requirements** = 7 ACH<sub>50</sub>  
Equivalent to 15" x 15" hole in home



**Energy Star 3.0** = 5 ACH<sub>50</sub>  
Equivalent to 13" x 13" hole in the home



**2018 IECC Requirements** = 3 ACH<sub>50</sub>  
Equivalent to 10" x 10" hole in the home



# What is Aeroseal Envelope?



- It is a proprietary technology that takes the guesswork out of air sealing and allows you to achieve consistent results.
- Can be applied at any time after rough-in and prior to occupancy, if the space can be pressurized
- Offers guaranteed, measured results
- Can seal leaks up to ½ inch





# How Envelope Sealing Works



SINGLE-FAMILY



MULTI-FAMILY



# Terminology-Building Terms /Metrics



- **Air Barrier** - systems of materials designed and constructed to control airflow between a conditioned space and an unconditioned space. The air barrier system is the primary air enclosure boundary that separates indoor (conditioned) air and outdoor (unconditioned) air. AeroBarrier is **not** a primary air barrier.
- **Building Envelope**- The conditioned space of a building that is enclosed by the Air Barrier
- **Pascals (Pa)** - the standard unit of pressure or stress in the International System of Units (SI), equal to one newton per square meter. ( example: 6,894pa = 1psi)
- **ACH50** - air changes per hour at 50 pascals (Pa) pressure differential. It is the number of times the air volume in a building changes per hour at 50 Pa of pressure.
- **CFM50** - the airflow (measured in cubic feet per minute) from the blower door fan needed to create a change in building pressure of 50 pascals.
- **Building Volume**- The total amount of the air enclosed inside of a building. It is measured in Cubic Feet(ft<sup>3</sup>)



Basic Building Science  
Terminology

# Terminology -Calculations



- Calculating Building Volume-When calculating building volume, you multiply the Square footage of the house by the average ceiling height( $\text{ft}^2 \times \text{avg H}$ )
- Calculating ACH50 using CFM50-To Calculate ACH50 using a CFM50 leakage, you multiply the CFM50 leakage by 60 and divide it by the building volume. ( $\text{cfm50} \times 60 / \text{ft}^3$ )
- Calculating CFM50 using ACH 50-To calculate CFM50 using an ACH50 leakage, you multiply the ACH50 by the building volume and divide it by 60. ( $\text{ACH50} \times \text{ft}^3 / 60$ )

# Terminology -Devices



- **Main Control Unit (MCU)** – The main machine in the Aerobarrier System. Contains the electrical outlets and Wi-Fi router
- **Sealing Stations** – The supplementary machines that distribute sealant in the envelope
- **Manometer**-Device used to measure the pressures of the envelope and blower door fan (AB connect uses a Retrotec monometer)
- **Envelope Pressure**- **Blue tube** the **positive pressure** of the envelope. It is measured in pascals. It requires **10 Pascals** or higher to calculate leakage
- **Fan Pressure Tube**- **RED tube** It measures the amount of **negative pressure** the fan is pulling. It is measured in pascals. It requires **-10 Pascals** or **Below** to calculate leakage. **Note:** On program's Pre-Seal/Post-Seal and sealing screens, this **(-10)** shows as a **(10)**
- **Blower Door** - a machine used to measure the airtightness of buildings. It can also be used to measure airflow between building zones, to test ductwork airtightness and to help physically locate air leakage sites in the building envelope.
- **Fan Inlet Ring** – Is an orifice used to restrict the amount of air going into the fan tighter ring  
= less outgoing air

# The Sealant



**AeroBarrier X1: An inert sealant** based on permeable waterborne acrylic

- Green Guard Gold Certified
- National Green Built Standard Certified Product
- Ultra-Low VOC (Volatile Organic Compounds) / No Off-Gassing

## Meets:

- ASTM 2178 - Air Sealing Material
- UL 263 (Fire Resistance)
- CAN-ULC-S101 (Fire Resistance, Canada)
- CAN-ULC-S102 (Flame Spread and Smoke, Canada)
- UL 2818 (Green Guard Gold Certificate)
- ASTM C719 - Sealant Durability
- ASTM D543 - Chemical Compatibility
- ASTM E2357 – Air Leakage in wall assemblies



# | Safety



- **Operation of this equipment can be hazardous due to mechanical and electrical components. Only trained / Certified Aeroseal Technicians should operate and service this equipment.**
- **When working on this equipment, observe precautions in the Operations Manual, on tag, and on labels attached to, or shipped with the equipment. Follow all safety instructions.**
- **Follow all local and national codes.**

## Section 2

# | Scope of Work



# Communicate to Builder

- Ensure the builder has the envelope ready for the seal
- Make sure the builder has parking space for the trailer within 100ft of the injection point.
- In cold weather, (below 50 degrees F) ensure builder has the structure heated
- Obtain the Structural Volume (from the plans) of the envelope to be sealed
- Avoid other subcontractors working on structure during the sealing process.





# Necessary Items to know Prior to Seal

- Square footage and building volume
- ACH50/CFM50 requirements
- Number of items needing to be prepped (windows, doors, etc.)
- Stage of construction of the structure to be sealed.



[Aerobarrier Site Survey Form](#)



## AeroBarrier Site Survey Form

### CONTRACTOR INFORMATION

Site Contact: Contractor Project Manager

Phone

Email to send seal certificate

### JOB INFORMATION

Site Address

AeroBarrier Technician Name(s):

# The Aeroseal Envelope Process



## STEP 1:

Prepare house for sealing. Cover all large DESIGNED openings (drains, bathroom vents, etc.) and horizontal surfaces. Set up sealing equipment and pressurize home.



# The Aeroseal Envelope Process



## STEP 2:

After baseline leakage is determined, pressurize the space and the sealing stations begin the sealing process



# The AeroSeal Envelope Process



## STEP 3:

*The software regulates the entire process; controlling all parameters, monitoring the sealing, recording all data, and verifying air-tightness target is achieved.*



The screenshot displays the AeroSuite 1.0.2.1 software interface. The top navigation bar shows the current step is 'Seal', with other steps like Preprep, Preseal, Postseal, Flush, Depressurize, and Results visible. The interface includes a progress indicator, a timer (00:19:46), and various control buttons (Pause, Stop, Start). Key parameters are displayed, including Ring Setting (5-inch ring), Target Pressure (200 Pa), and Use Heater? (Non-Electric). A Fan speed gauge is shown at 67%, and a control panel for the fan is set to Automatic. Real-time data for Envelope Pressure (199.8 Pa), Fan Pressure (334.5 Pa), and Fan Flow (436.2 CFM) is provided. The Envelope Leakage section shows 292.5 CFM50, 35.2 Sq.In., and 1.3 ACH50. A graph displays Leakage @ CFM 50 over time, with a target line and an 'Op. Leakage' bar. The Seal Stations section lists 2 stations ready to seal and 0 disabled stations. Environmental data includes Inlet Humidity (24.7%), Inlet Temp (73.8 °F), and Compressed Air (106.2 PSI). A QR code is visible on the left side of the interface.



# Types of Leakage Sealed

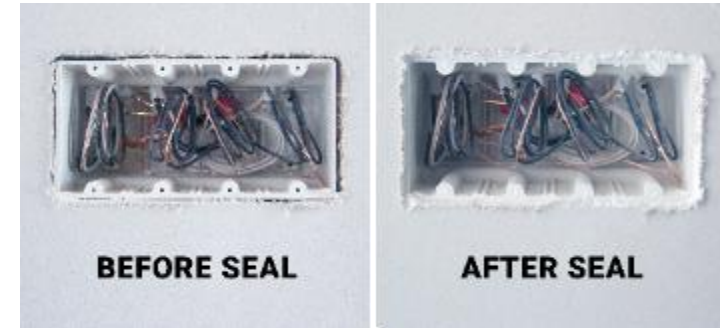
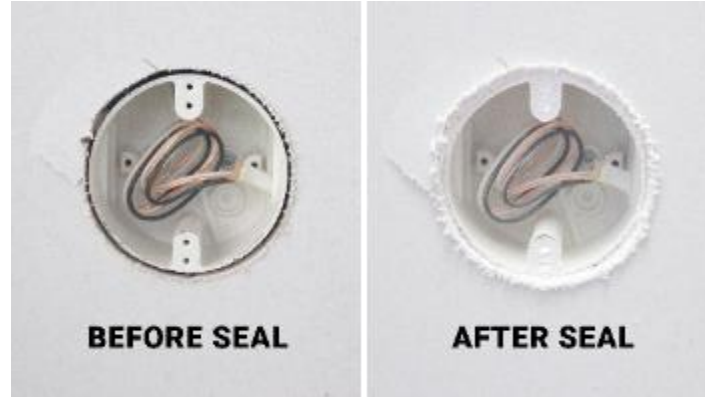
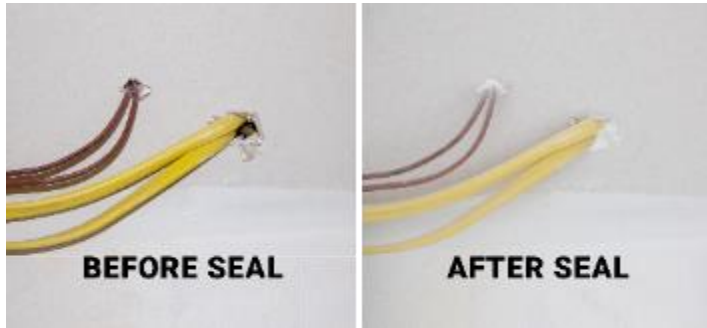

Section 3

| SET UP & SEALING

STANDARD OPERATING  
PROCEDURE

# Arriving at the jobsite

- If possible, position equipment in an area away from wind and rain. (i.e. garage)
- Make sure other trades are out of the envelope during sealant injection
- Determine blower door/fan injection point, seal station location and quantity of seal stations.
- Locate big openings and entry / exit points.
- Walk through envelope to scope amount of prep-work and look for any unforeseen prep work (i.e. missing windows, chase walls etc.).



# Prepping the Envelope for Seal



Preparation of the envelope is the most time-consuming part of the job

The Goal:

Prep the house to ensure:

- Minimal clean up
- Protection of designed opening and other components within the space that you don't want to be sealed
- Maximum seal efficiency

Understand why we prep

Understand the implications of prep work



1 - Scoping out the Jobsite for Prep





# Prep Work Outline



What to look for:	How to Prep:
Big Holes	Manually block (with foam or duct mask) or seal with caulk/can foam
Vents	Use duct mask on all HVAC supply and returns (ensure the gap between the duct boot and drywall is left open so it can be sealed). All exhausts grills, bathroom vents, and kitchen vents should be temporarily covered.
Designed Openings	Cover and protect any designed opening in the space to ensure they don't get sealed
Windows	Check windows to make sure that they are all closed tightly and LOCKED
Doors	Tape top of doors and cover and finished surfaces (i.e. sliding door tracks)
Finished Horizontal Surfaces	Any finished horizontal surfaces in the house should be protected for easy clean up
Plumbing	Check for plumbing penetrations and block or seal any holes larger than ½"
Electrical	Remove any switch and outlets plates. Tape/protect main electrical panel and low voltage/data panel
HVAC Equipment	Cover up and protect any mechanical equipment
ERV	Tape or cover the outer shell of the ERV. Look for the piping between HVAC and ERV and block the holes
Light Fixtures and Fans	Cover and protect any light fixtures or fans with plastic
Fireplace	Cover fireplace completely, including vent holes. Look for any other ventilation in the drywall or framing into the fireplace

(See Envelope prep Checklist in Appendix section for more details )

## Fully Ducted System

The most desirable configuration. Highly recommended to get the best results in all climate types.

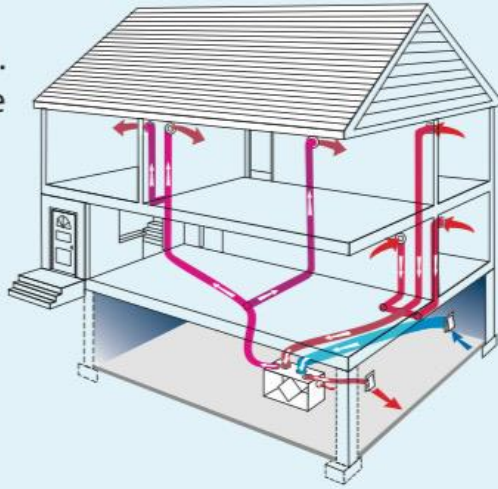

## Dedicated Exhaust Points with Distribution of Fresh Supply Air through the Central H/AC System

A hybrid approach that allows the system to be an effective exhaust fan, while taking advantage of the central H/AC duct system to distribute fresh air. Maintaining unit balance is often challenging.

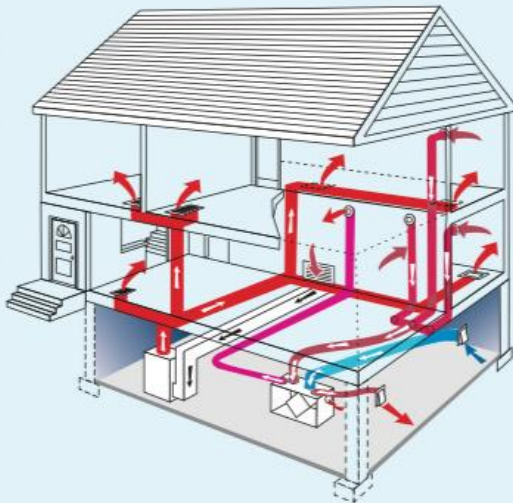

## Exhaust from H/AC Return and Distribution of Fresh Air through H/AC System

The least desirable solution because it is difficult to assure balanced airflow and can cause moisture problems in duct during warm, humid seasons. Requires knowledgeable installer.

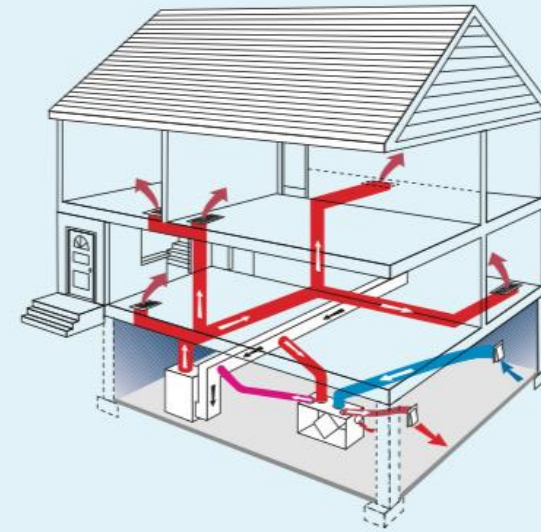



# Common Manual Sealing Points

- For holes larger than ½", manually seal with spray foam/caulk



Manual Sealing in Aeroseal Envelope

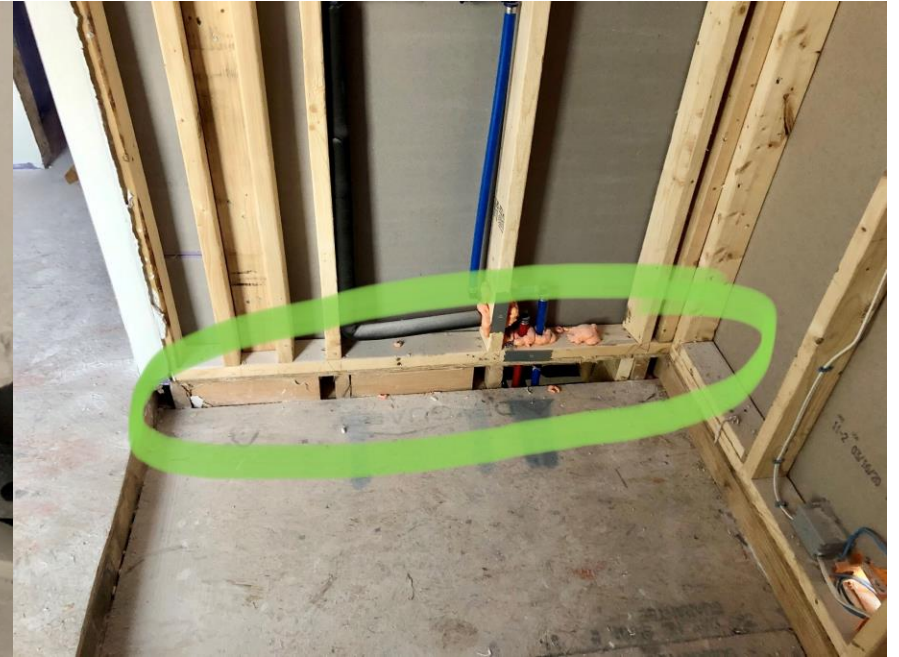
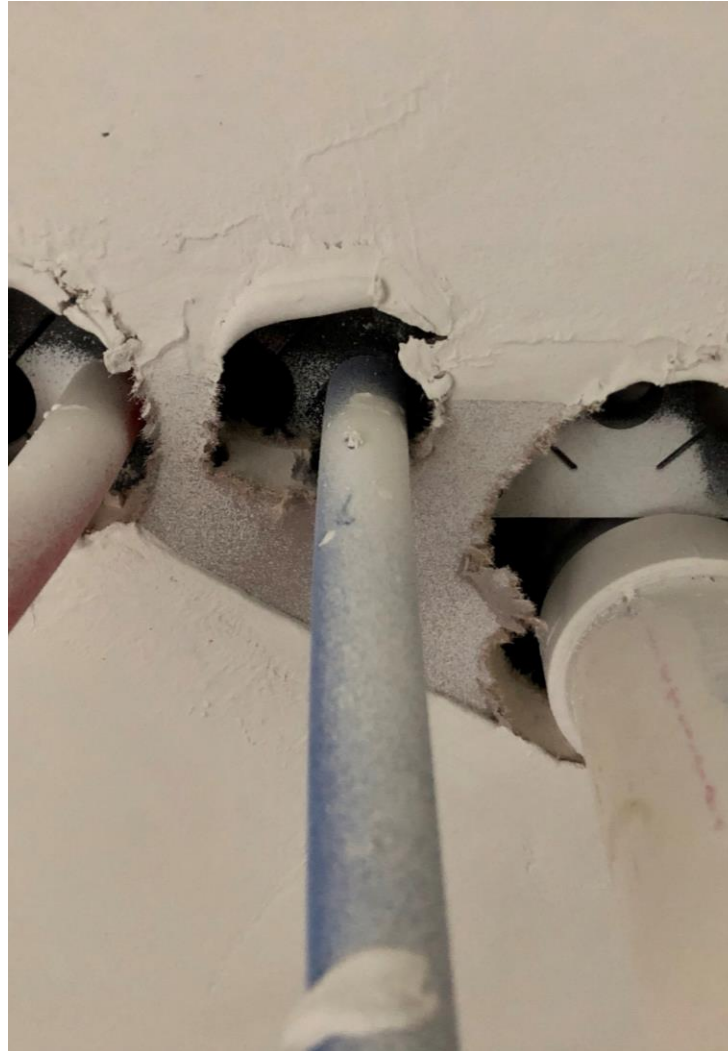

# Windows and Doors



How to prep a door



How to prep a window



Window and Door Prep



# HVAC/Bath/Range Hood Vents

Boot Leakage in Envelope Sealing



Ensure gap between drywall and HVAC register (boot leakage)/Bath fan frame are either manually sealed with caulk/sprayfoam if  $>1/2''$  or left open for Aerobarrier to seal if  $<1/2''$

Prep of the Exhaust and HVAC Ducts

# Attic/Crawlspace Accesses



For attic and crawlspaces, we need to tape off the perimeter of the access doors to seal it off. If the temporary hatch or door is missing, we will have to use a barrier material such as green tape, plastic sheets, or plywood to block them off.



Covering missing door



# Finished Horizontal Surfaces



Prep of Finished Surfaces & Spec App



Tub prep is simple, just make sure the drain, spout and breather port are taped off.



Cover **any** finished surfaces, including floors, exposed to sealant.

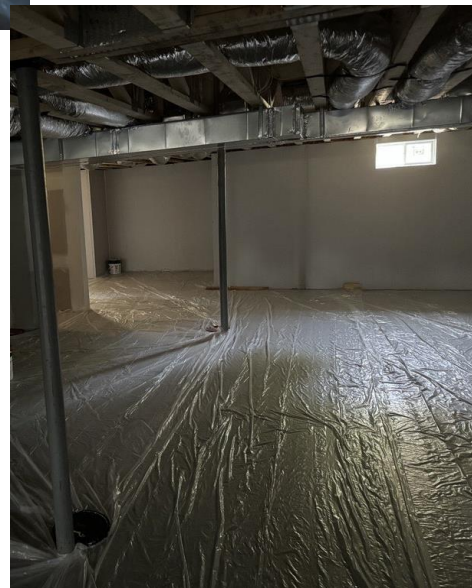

COVER WINDOW FRAME  
"WEEP-HOLES"  
FROM SEALANT  
DEPOSITION



# HVAC Equipment & Fireplace Prep



Prep of the Fireplace and HVAC



# Blower Door

- The Blower Door is a Frame with a nylon canvas that has an opening for a fan
- This blower door frame is what allows the envelope to be pressurized for sealing



Link to Setting up a  
blower door video



# Pre-Prep (Baseline) Leakage Test

- To prevent any unforeseen issue (High leakage, failed blowerdoor tests, Etc.) Set up MCU & AB Fan and do a **pre-prep** test without any prep to get a feel for how much window/door leakage there is in the house.
- Once prep is done, do the **pre-seal** to see what the leakage is without the window/door leakage.
- Use that delta between pre prep blower door test and post seal blower door test to determine what ACH/CFM to seal down to

(Note: This step is required to prevent any failed blower door tests)



# Seal Station Layout

- Identify amount of seal stations to use (**Generally 1 Seal Station per 500-700 sq ft. floor area/layout of the envelope**)
- Orient nozzles away from walls
- For very small rooms –
  - locate station in the corridor
  - Use each nozzle for adjacent rooms
- Locate Blower door in a garage/ accessible place where MCU can be located
- Identify additional entry/exit door in case you need to enter the house being sealed during the job.

➤ See subsequent slides of example layouts



Link to-Sealing station/nozzle positioning in Aeraseal Envelope video

Legend for floorplan examples in next pages

The legend is enclosed in a blue rectangular border and contains three items:

- Seal Station location and Nozzle direction:** Represented by a black tripod icon with a red square border. Two red arrows point from the top of the tripod towards the top-right and bottom-right.
- Blower door location:** Represented by a small photograph of a red blower door unit in a room.
- Where to move seal stations:** Represented by a blue four-pointed star icon with arrows pointing outwards in all directions.

# Layout 1: Sealing Station and Blowerdoor Layout





# Layout 2: Sealing Stations and Blowerdoor Layout



Once, the Blower Door has been installed, a service door has to be available to enter the house during the seal event if necessary

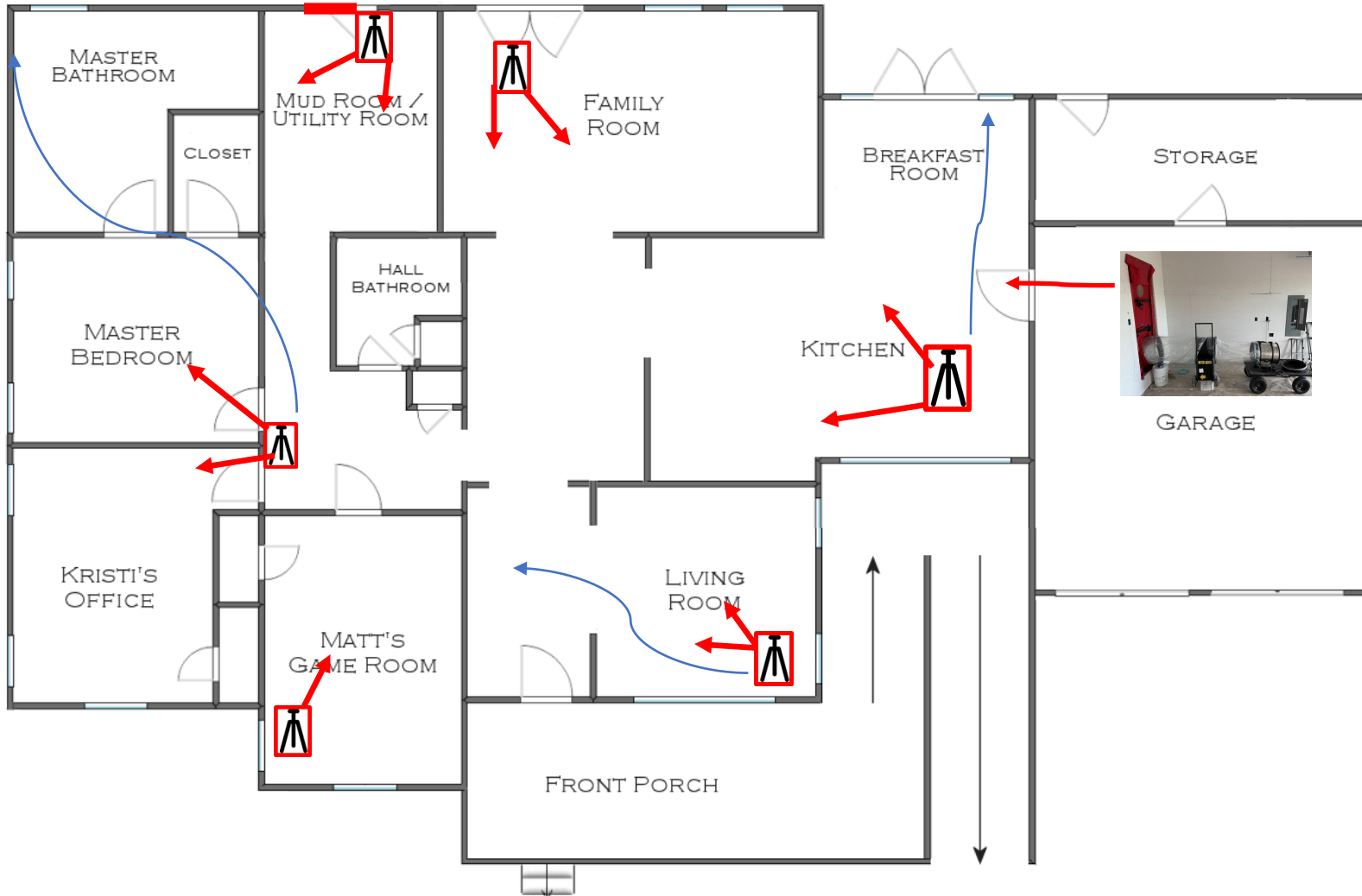

This layout shows a 6 nozzle setup. With all the small rooms it makes it difficult for the nozzles to get ample coverage. This setup shows the blower door centrally located to cover the majority of the home.

# Layout 3: Sealing Stations & Blowerdoor Layout

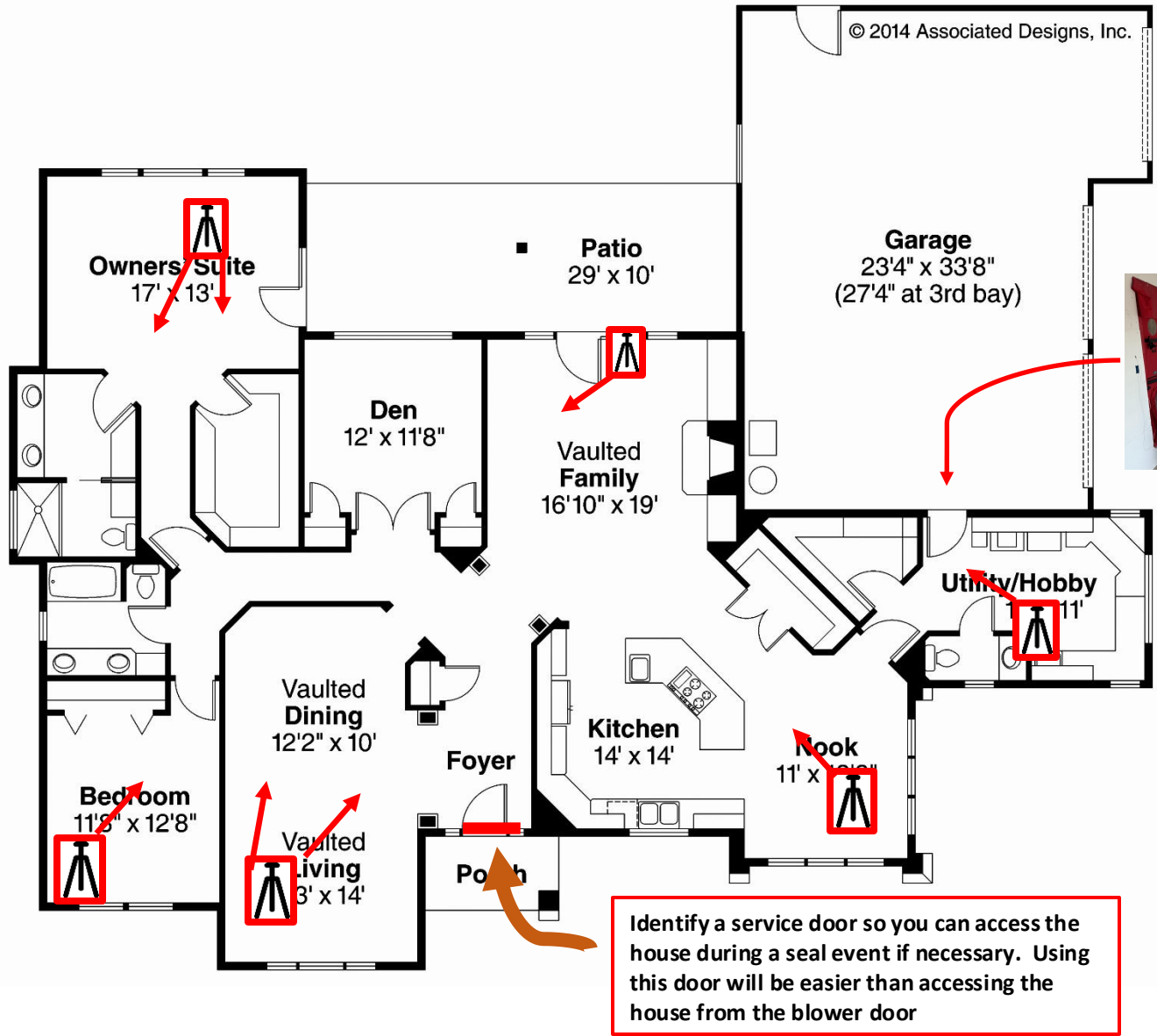

This example shows a blower door setup in the garage pressurizing the home. This setup allows the equipment to be stored inside the garage and is ideal for cold weather applications





# Layout 4: Sealing Station & Blower door Layout

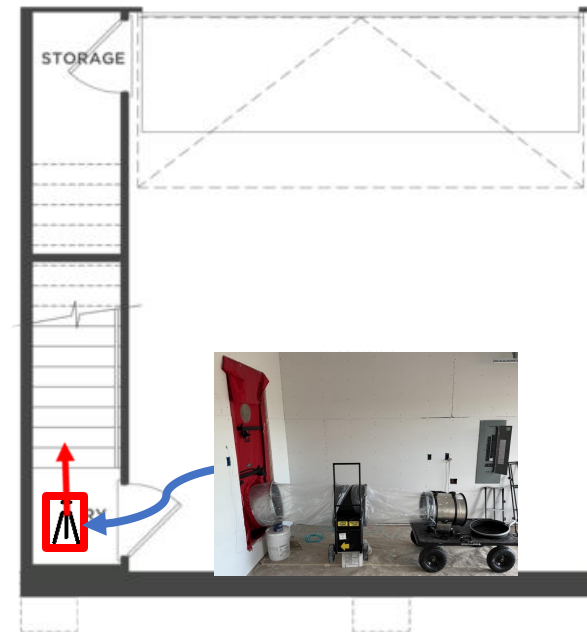
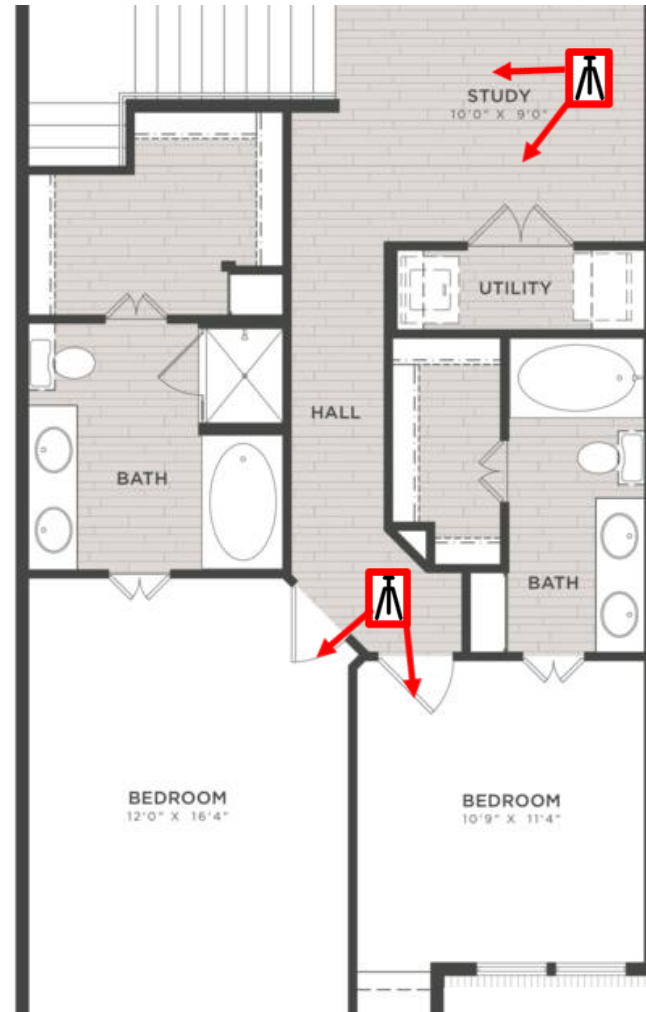



2024

---

Section 4

AEROBARRIER SELECT  
EQUIPMENT

# AeroBarrier Select System

- Main Control Unit (MCU)
- Sealing Stations
- 120V Fan
- Non-Electric Heat (NEH)



Practice seal set-up  
video



**Main Control Unit**



**Sealing Stations**



**120V Fan**



**Heater System**

# Important Accessories



Air Manifold



30 ft Air Hose



Sealant Transfer Pump



Link to Aerobarrier accessories video

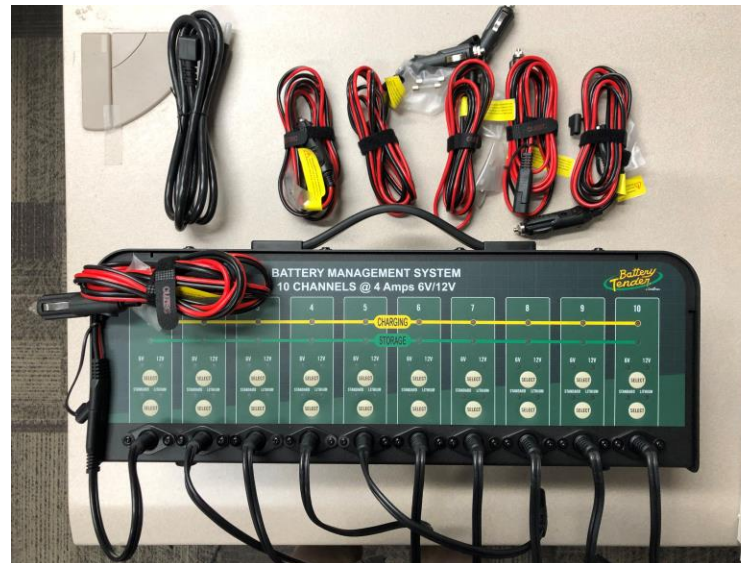

Charging Station

**NOTE: WHEN CHARGING, SET FOR "LITHIUM BATTERY"**



# Component Assembly





# AeroBarrier Select Main Control Unit (MCU)



- The “Brains” of the AeroBarrier Process.
- Contains the laptop and all components that measure and control the process.
- Has a Wi-Fi router which the smart sealing stations automatically connect to.
- Contains a set of sensors that measure ambient conditions
- Connects to the software via Wi-Fi or USB



Power input -Required Input power to MCU is 110V, 15A Single Phase



# MCU Panel

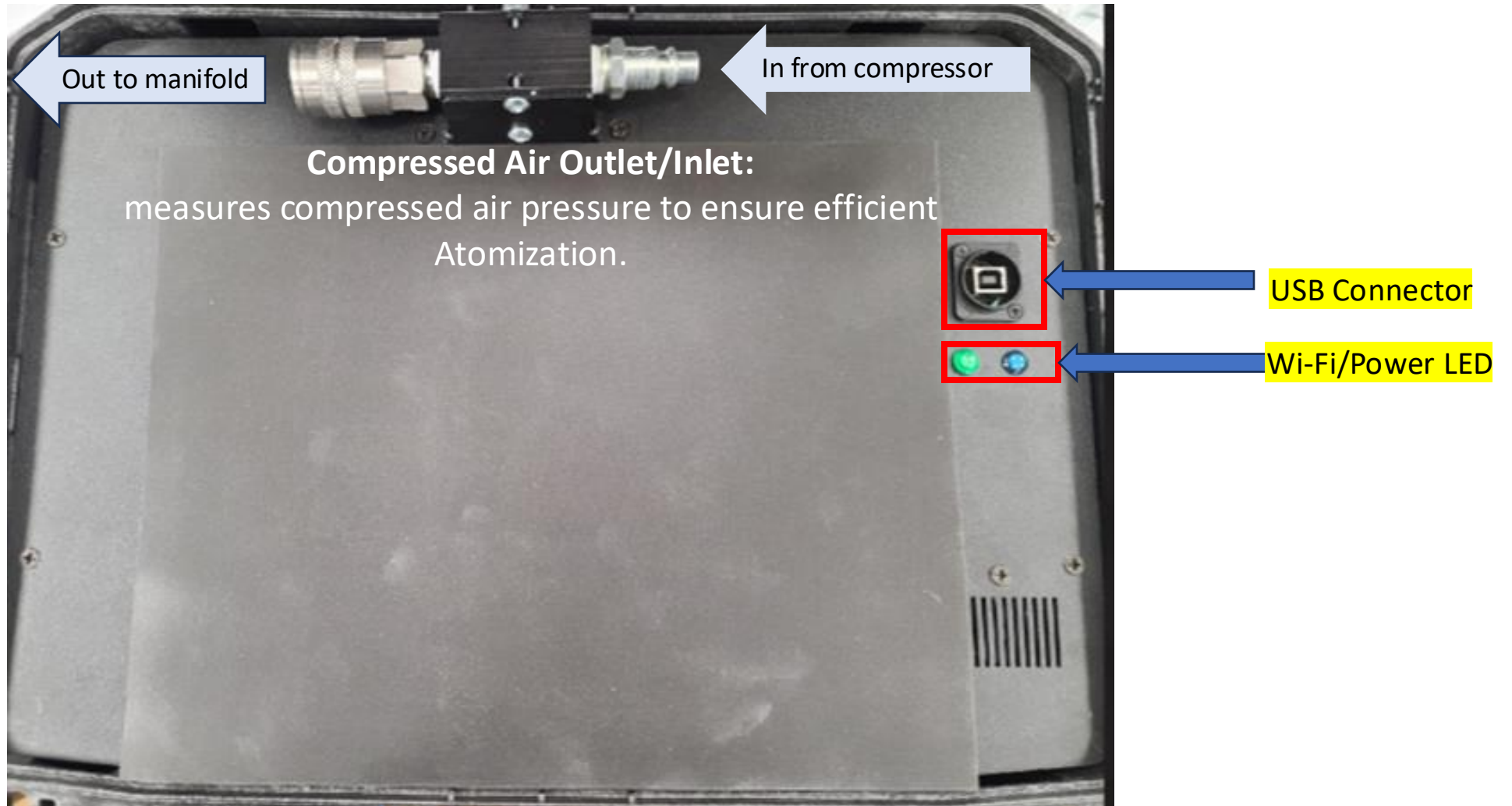

# Smart Sealing Stations



Link to Aerobarrier  
Sealing stations video

# Inside Seal Station

- Each sealing station is powered by lead acid sealed battery
- Has sealant & flush pumps
  - to push sealant to nozzle
  - To flush lines with water
- Has self-contained sealant & water jugs



Stir sealant prior to filling sealant stations

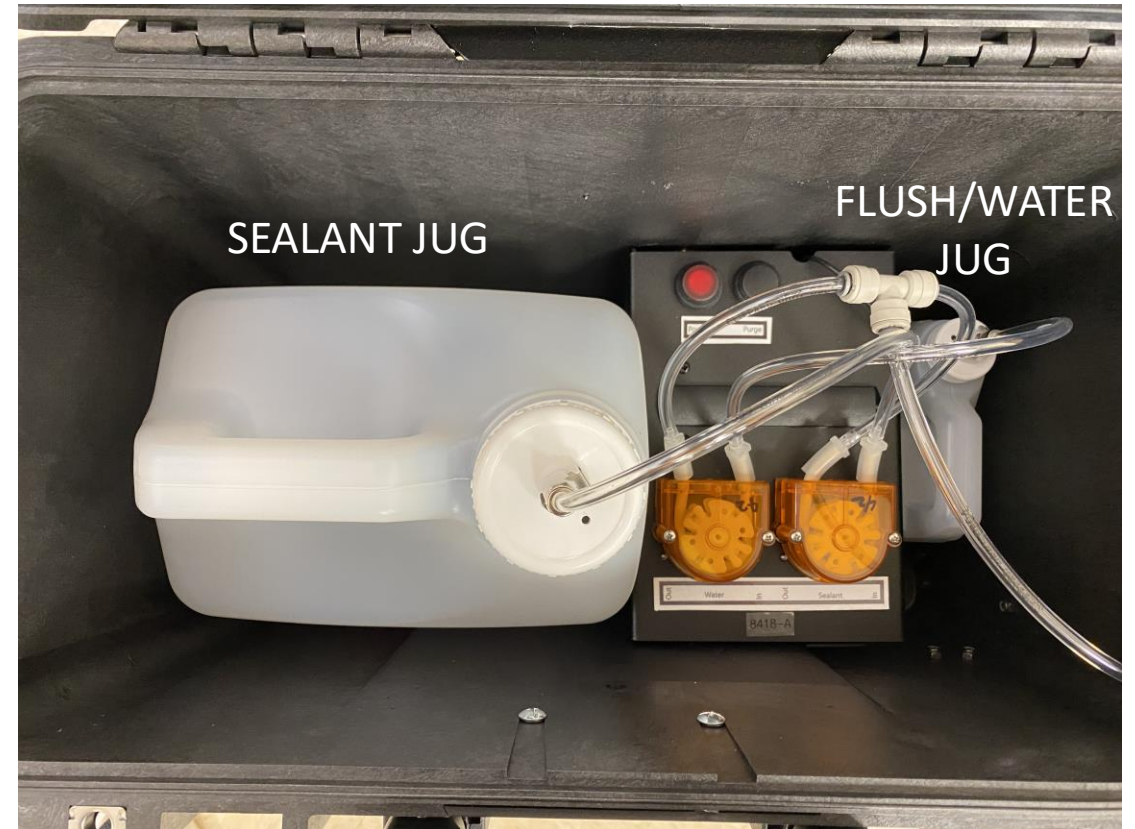



# Inside Seal Station (Cont'd)

- The sealing station has two buttons. The red button is to power on the seal station. The black button is the primer/purge button
- The pump labelled Sealant (Blue Arrow) will pump sealant while the other pump (Red Arrow) will pump flush water.

1. Stir the sealant in 5gal bucket completely
2. Fill the sealant jug in the spray station with sealant
3. To Prime, press the black purge button and sealant travels through tubing to the nozzles

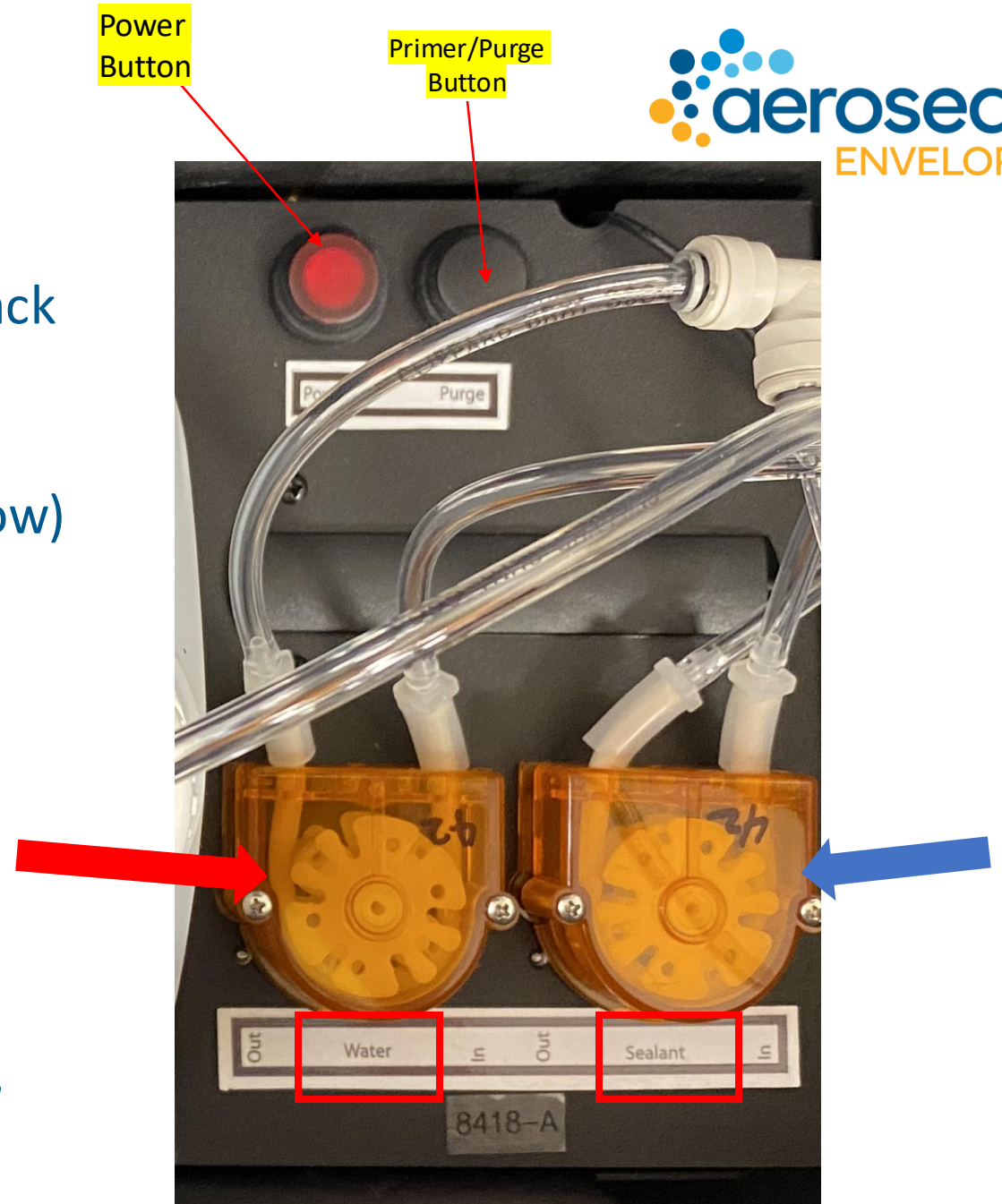



# Sensor Guard

- Takes zone temperature/RH readings at each smart sealing station.
- If RH goes higher than 90%, seal station will automatically stop injecting sealant. Will resume /reset at 70%
- Note: Temperature/Humidity limits for sealing are as follows:
  - Temp: Min 40°F - Max 120°F
  - RH: No Min - Max 90%
- Note: the position and orientation of the sensors is critical.



# Charging Port

- Used to charge the battery in the seal station
- Requires a 12V/DC charger (provided)
- After 10 hours of run time, it is important to charge the sealing stations
- Note: Set charger to “Lithium Battery” when charging stations

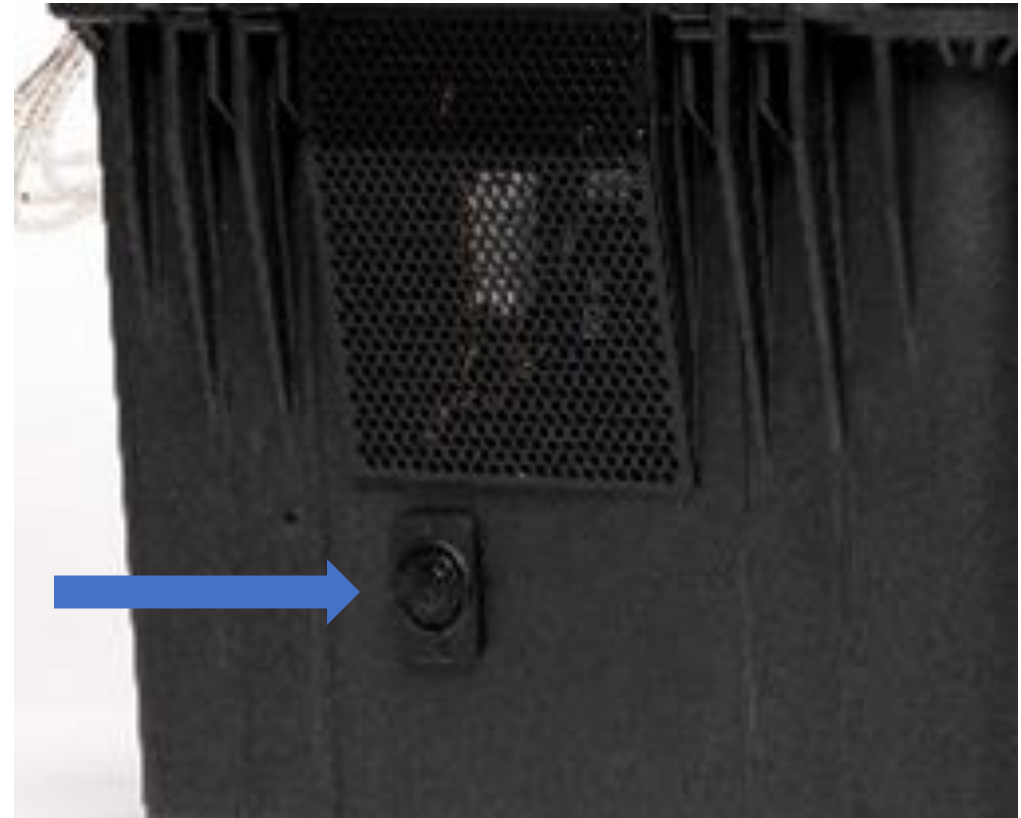

# 120V Fan

FRONT VIEW



Aerobarrier Select 120v fan video

# Back of Fan

Ring assembly consisting of 3 ring setups

- No Ring (Highest Flow)
- 5" Ring (Middle Range Flow)
- 2.5" Ring (Lowest Flow)

•Fan Pressure connection point (brass bulkhead) where the red tube is connected.

The Ring openings are calibrated orifices and care needs to be taken to avoid any damage – else you risk incorrect leakage readings

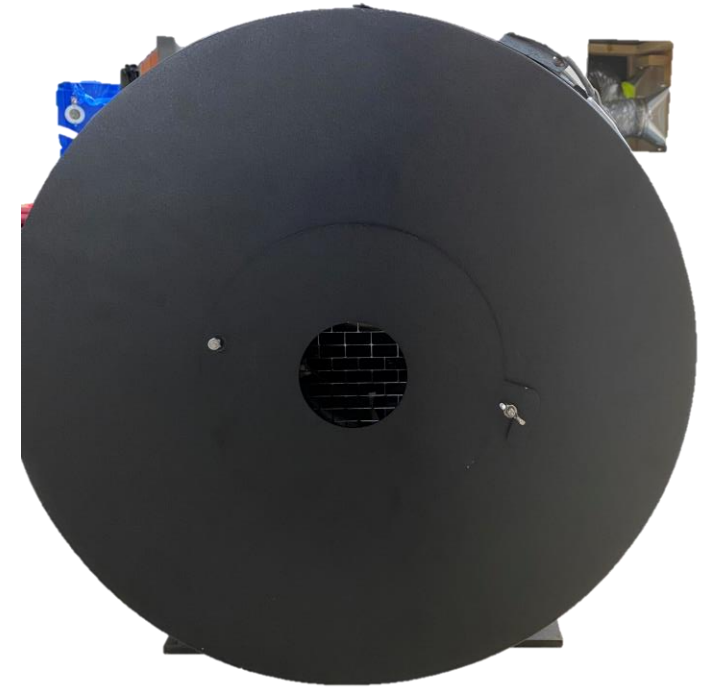



# Fan Control Box



# Fan Control Box Panel

## LED Status

- Power – This indicator lights up when the control box is powered on.
- VFD – This indicator shows green when the motor drive is operating correctly.
- Manometer – this indicator shows green within 1 minute of power on when the manometer is operating correctly.
- Data – This indicator turns green when connection with MCU has established and it blinks Red when data is received from the MCU.
- Fan – Only lights up when fan is running

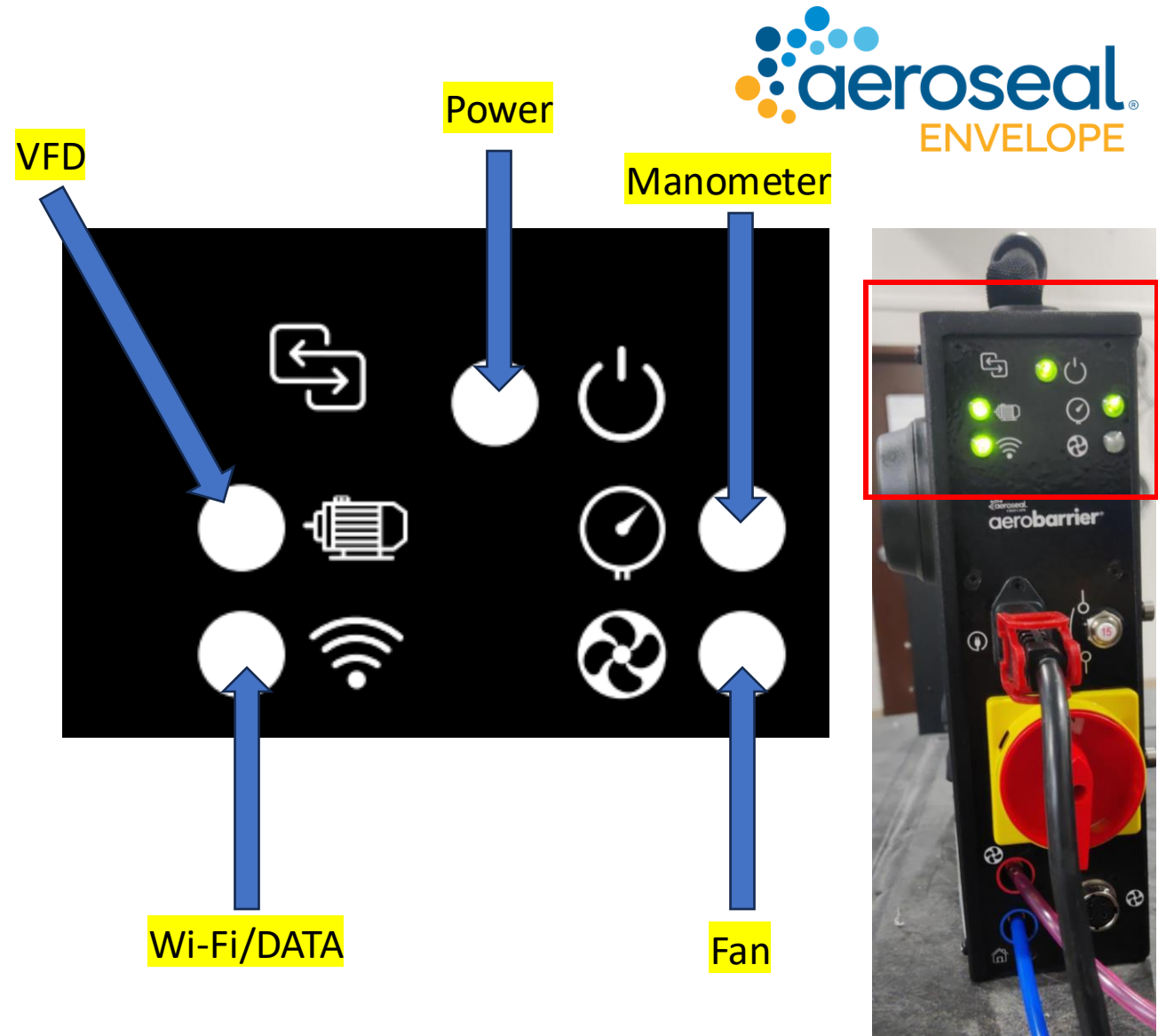

# Pressure Connections

- The fan control also incorporates a calibrated manometer, signal interface boards to communicate with the laptop.
- The pressure signals from the fan inlet (red tubing) and the envelope pressure (blue tubing) are connected to fan control box as shown
- The software uses the Fan Pressure and the ring settings on the fan to calculate air flow supplied into the building envelope.
- The brass bulkhead ports on the **back** of control box are atmospheric pressure **reference ports** for the manometer. Each is used as a reference for envelope or fan pressures.

**Good Pressure readings is key to correct Leakage (or ACH) numbers. Ensure the tubes are connected securely**

FRONT PANEL



REAR PANEL



# Non-Electric Heater System



Aerobarrier Select heater system  
Video



# Heaters

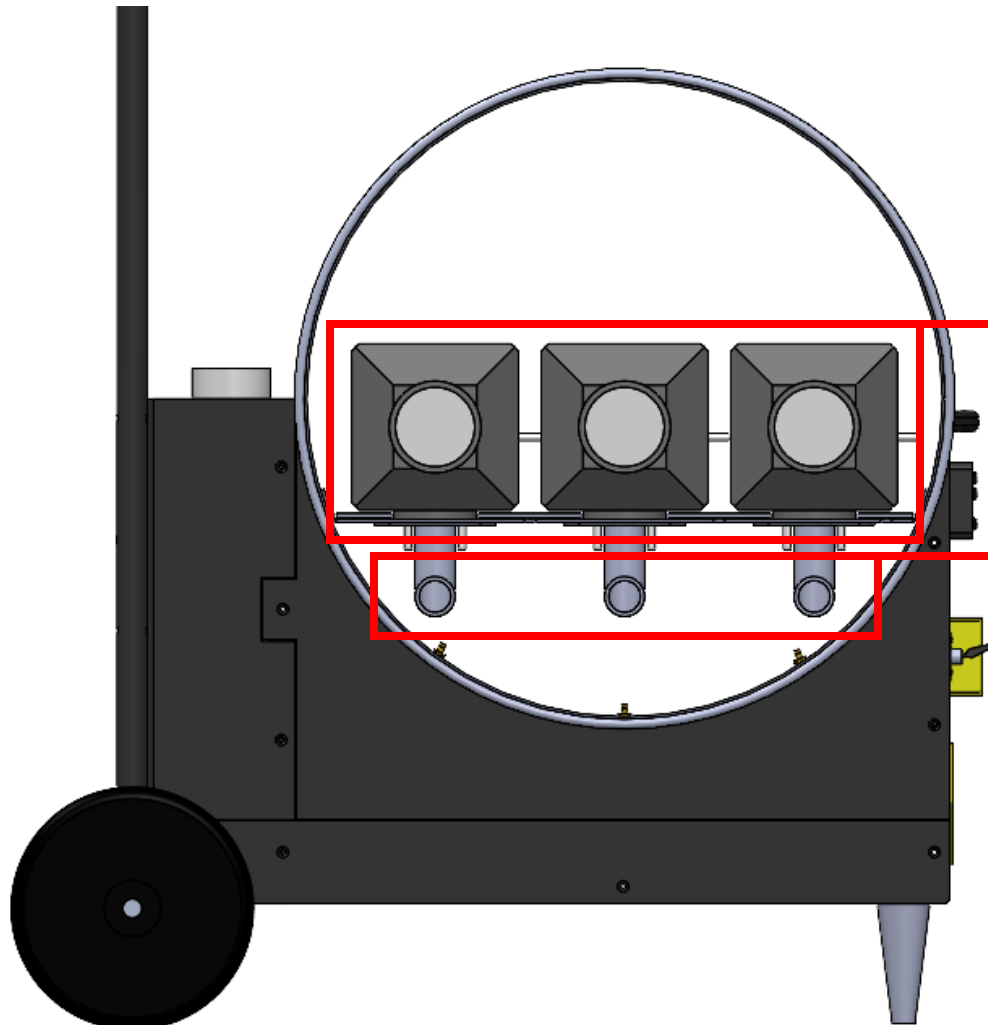

## Heaters

- Diesel combustion heaters
- 11kw total

## Intake/Exhaust

- Takes air from flow to feed combustion
- Puts heat into air flow (goes into house)

# Diesel Heater

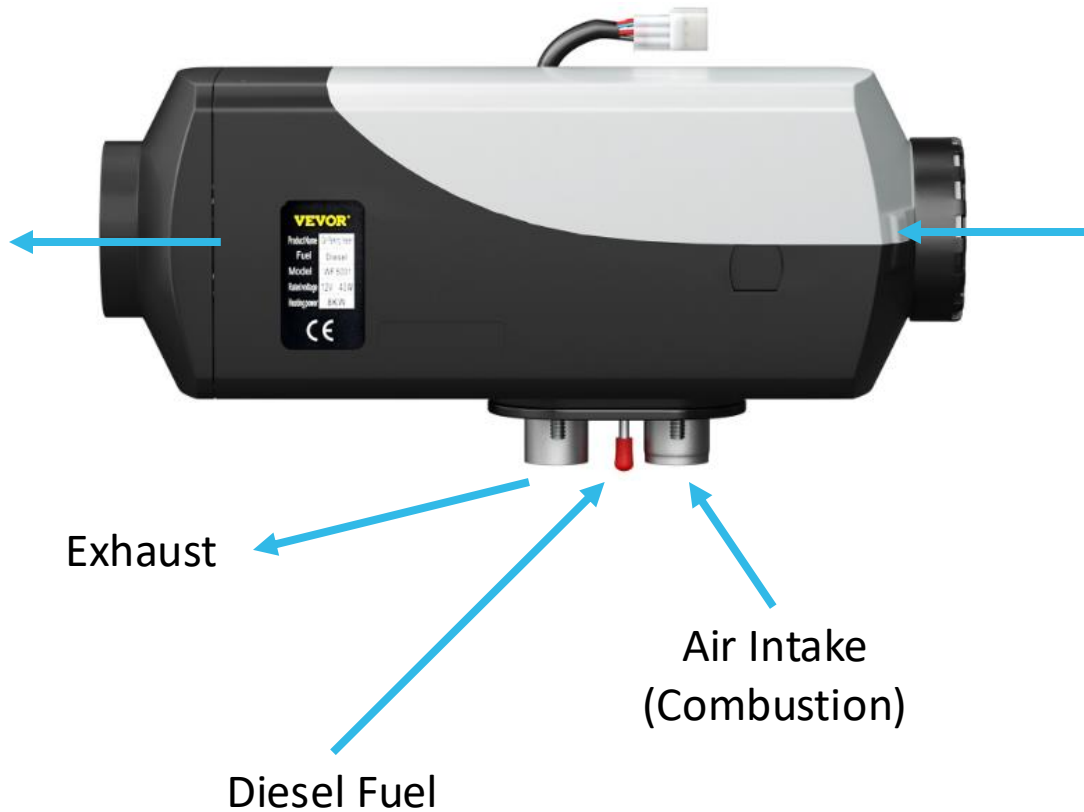

- Three Heaters within cylinder
- Full DIESEL fuel tank will last roughly 3 hours of runtime

# Control Panel

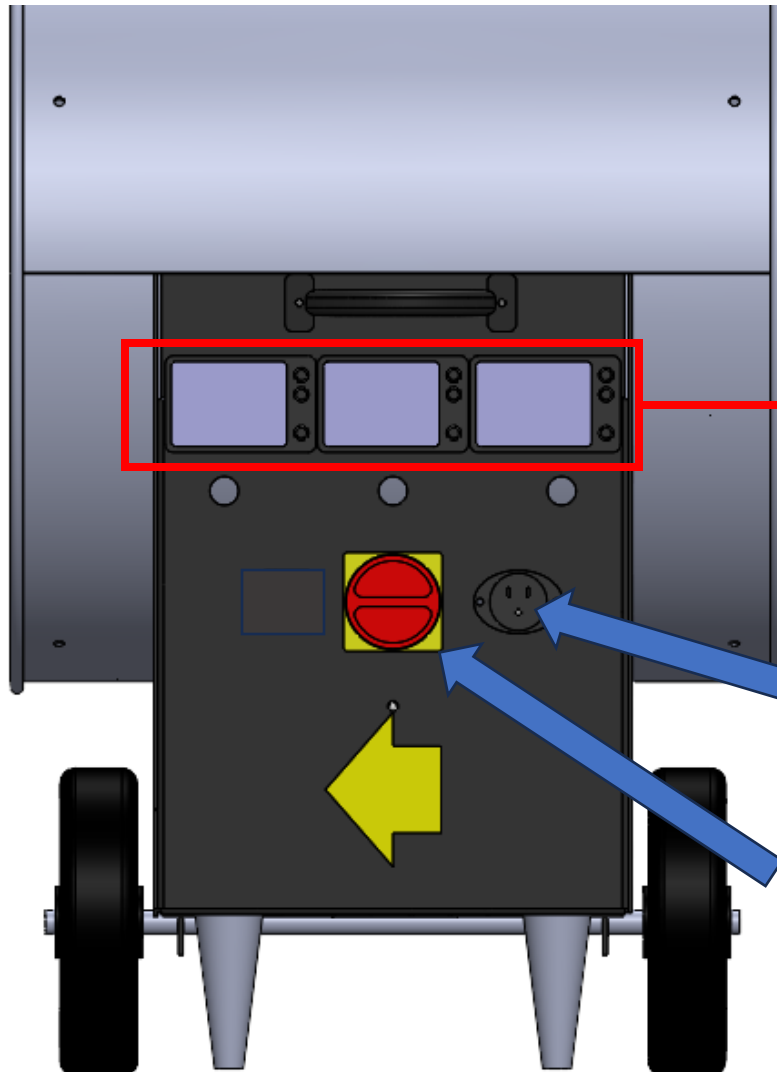

LCD Screens

- Each one is used to control a heater
- Always use this to shut down- Unless emergency
- Always use all three heaters

Power Input

E-stop

# Fuel Tank

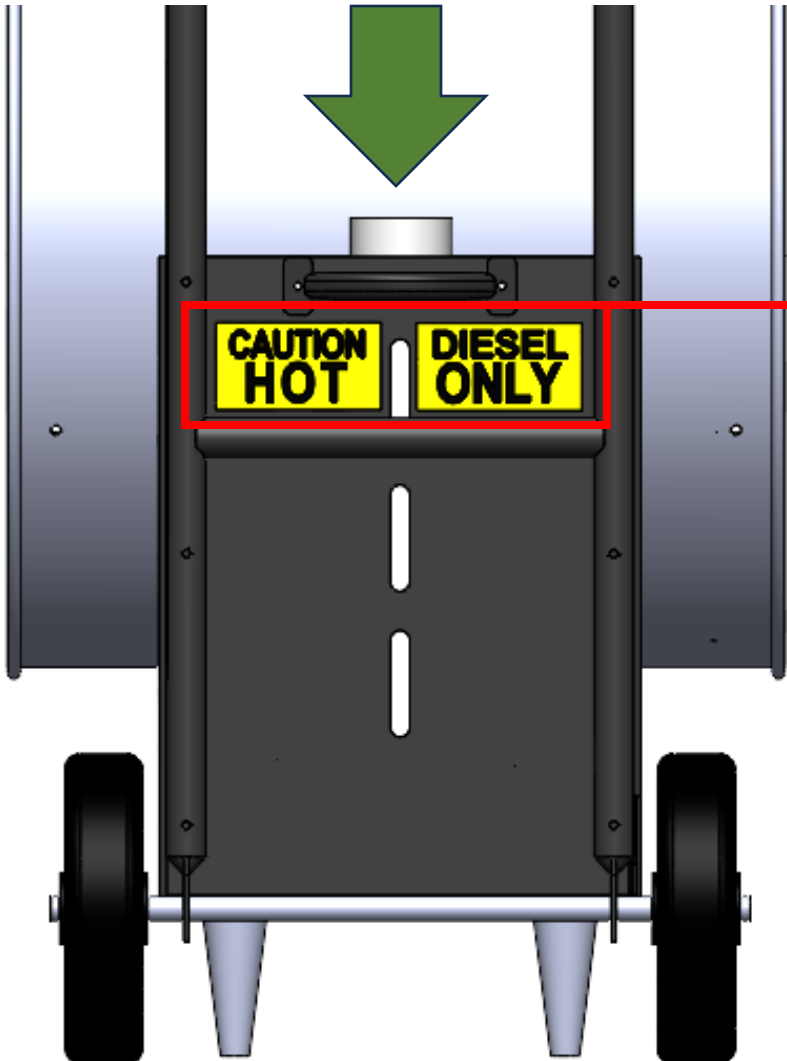

Caution label

- Reminder that surfaces may be hot
- Reminder to only use diesel with these heaters.



# Heater Setup

- **ONLY RUN THE HEATER DURING THE SEAL**
- The heater will go in between the fan and the blower door
- 3ft of layflat fan-heater & at least 6ft of layflat heater-blower door
- When seal is up and running, press and hold the power button on each LCD to turn the heater on
- Click the “UP” button until it gets to H6 (3 times)

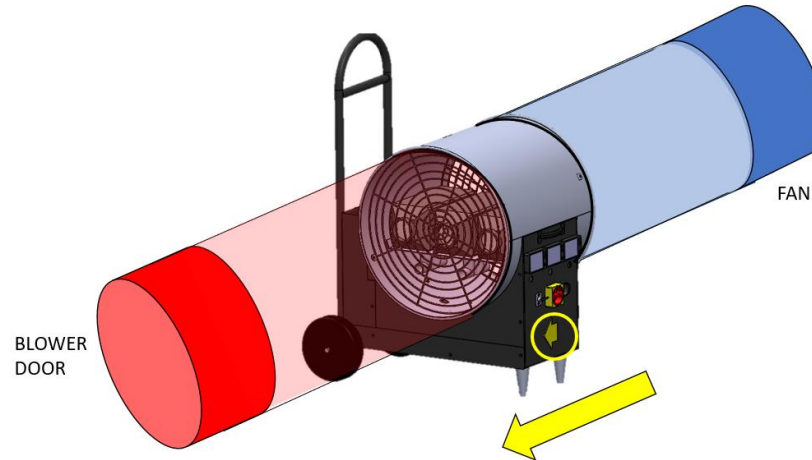

On Power-Up



After Pressing Power



After Turning Up Heat

# Cool Down

- Press and hold power button – heater will start proper shut down process
- Fan running during post-seal and house de-fogging will help cool down heater
- NOTE: Good handling to never get used to touching the grate – always use handles
- Grate takes roughly 1.5 minutes to cool down to handling temperature





Initial Start Up of AeroSuite

Section 5

| AEROSUITE SOFTWARE

# Starting the Aerosuite Software

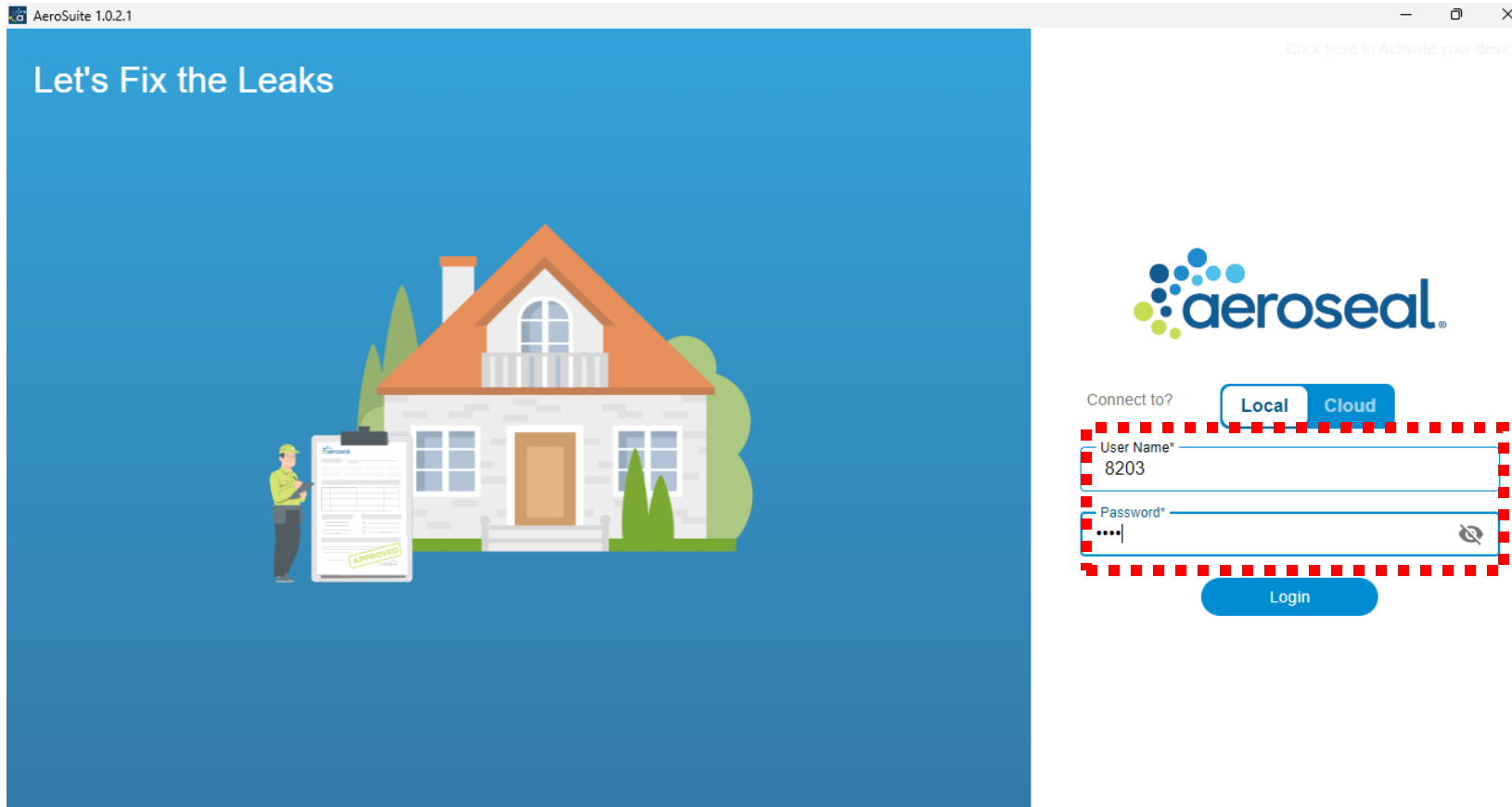

Link to-Sealing with the  
Aerosuite software  
video

Enter username and password to Login  
*Username: CASE ID*  
*Password: CASE ID*

## PRO-TIP

**Make sure that you do not have any pending Windows Updates on your laptop**



# Dashboard



1. Main Menu

2. MCU connection status (Green=connected/Red=disconnected)

3. Notification Bell.

4. Recent seal layout.

5. Project cards with color indication of the job status and seal preview.

6. Weekly count of seals

7. Upload/Sync data to Aeroseal

8. New Project button

Project Name	Address	Status	Completion
Final Test	225 Byers Rd.	AB   8203U   2/21/2024	1 of 1 completed
Alex Contracting Ilc	123 Test	AB   8203U   2/16/2024	0 of 1 completed
Alex Contracting Ilc	9075 Byers Rd	AB   8203U   2/16/2024	0 of 1 completed
Alex Contracting Ilc	123 wall Street	AB   8203U   2/15/2024	0 of 1 completed

Project cards: All seals completed | All seals not completed | No seals started

# WiFi – Connection Status



Sprayer Icon Will show how many Sealing stations are connected.

Ensure the Briefcase is green. If not connect to the MCU WiFi

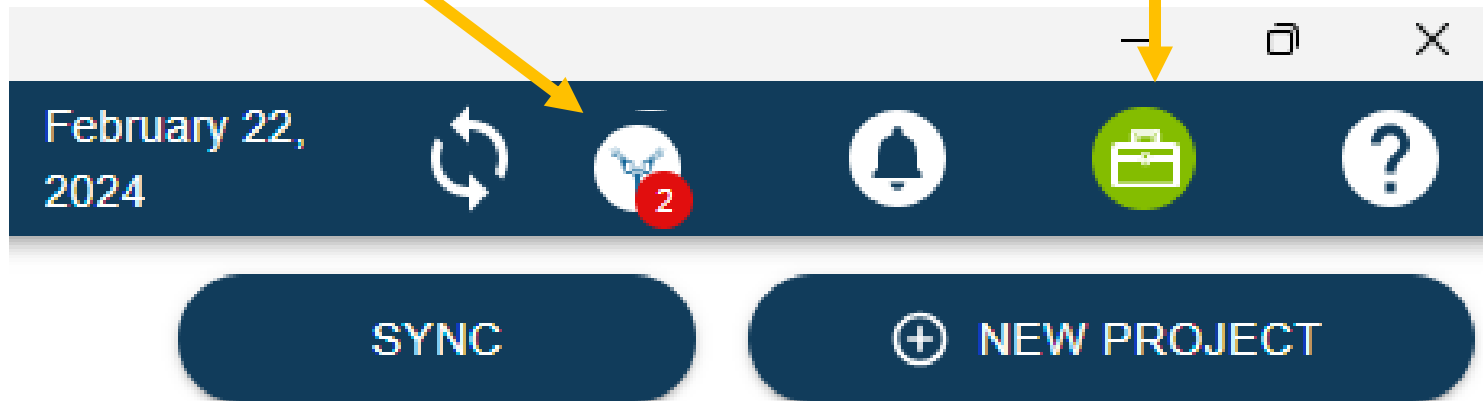

Sync your software with Aeroseal at least once per month

# SETTINGS – REGISTRY



AeroSuite 0.3.0.0

Registry 9978 June 27, 2024

Dashboard  
Projects  
**Settings**  
Release Notes  
Logout

**Registry**  
Profile  
About  
Preferences  
Pairing

**Case Id: 9978**

**Software Information**

Type Of Hardware	AeroBarrier Select
Wireless MAC Address	-
License Type	AB
Type of Connection	-

CONTAINS BASIC INFORMATION ABOUT YOUR SYSTEM

# PROFILE -Enter Your Company Information



AeroSuite 1.0.2.1

aeroseal

Profile 8203U February 22, 2024

Registry >

**Profile >**

About >

Preferences >

Dashboard

Projects

Settings

Logout

**Dealer Information**

Certificate Contractor Name\*  
Final Test

Address\*  
225 Byers Rd.

City\*  
Miamisburg

State\*  
OH

Zip Code\*  
45342

Country\*  
USA

Mobile Number\*  
(123) 456 7890

Fax Number

Email\*  
123@gmail.com

**Upload Dealer Logo**

Click here to upload a logo

Clear

Supported formats JPG, PNG; Image Size: 200px x 100px Max; File Size: 2MB Max

Save



# SETTINGS – ABOUT



AeroSuite 0.3.0.0

9978 June 27, 2024

Dashboard  
Projects  
**Settings**  
Release Notes

Registry >  
Profile >  
**About >**  
Preferences >  
Pairing >

### Software Version

AeroSuite	0.3
Database	-
Core	-
Firmware	-

Copyright ©2024 AeroSeal LLC

### Contact Information

- 800-772-6459
- support@aeroseal.com
- http://www.aeroseal.com

Check for Updates

Logout

## CONTAINS INFORMATION

- TECH SUPPORT NUMBER
- ABOUT SOFTWARE VERSION
- AND TO CHECK FOR UPDATES

# SETTINGS – PREFERENCES



AeroSuite 0.3.0.0

9978 June 27, 2024

Registry >

Profile >

About >

**Preferences >**

Pairing >

Language Setting  
English (United States)

Units of Measurement  
US Unit

Certificate Option  
Seal Report

Save

Dashboard

Projects

**Settings**

Release Notes

Logout

MAKE PREFERENCE SETTINGS HERE

# New Project



AeroSuite 1.0.2.1

Dashboard 8203U February 22, 2024

Dashboard Projects Settings

## Welcome Technician User

5 Lifetime Total Seals 2291 Lifetime Total CFM

SYNC NEW PROJECT

Seal Count

Last Month Current Month

Week	Last Month	Current Month
Week-1	0	0
Week-2	0	0
Week-3	0	5
Week-4	0	2
Week-5	0	0

Recent Activity [View All](#)

Activity	Location	Date	Status
Final Test	225 Byers Rd.	AB   8203U   2/21/2024	1 of 1 completed
Alex Contracting llc	9075 Byers Rd	AB   8203U   2/16/2024	0 of 1 completed
Alex Contracting llc	123 Test	AB   8203U   2/16/2024	0 of 1 completed
Alex Contracting llc	123 wall Street	AB   8203U   2/15/2024	0 of 1 completed

Logout

# Select Job Type

AeroSuite 1.0.2.1

February 21, 2024



aeroseal.

Dashboard

Projects

Settings

Logout



Envelope - Single Seal



Envelope - Development/Community

# Single Seal Option



AeroSuite 1.0.2.1

8203U February 22, 2024

**Single Seal Project**

Builder Name\* Aerobarrier Builders

Address\* 225 Byers Rd. ZipCode\* # 45342

City\* Miamisburg State\* Ohio Country\* USA

Email Mobile Number

Sq. Footage\* 1500 Leakage Target\* 3 Units ACH50 Avg. Ceiling Height (ft) 9 Struct. Volume (ft³)\* 13500 Construction Phase\* Post-DryWall

Number of Stories\* 1 on slab Insulation Type\* Batt Building Type\* Single Family ...

**ASTERIX ARE REQUIRED FIELDS**

Notes

Attachments

Logout Continue Sealing Save



# Select Job Type



AeroSuite 1.0.2.1

February 21, 2024

aeroseal.

- Dashboard
- Projects
- Settings

Logout

aeroseal ENVELOPE

Envelope - Single Seal

Envelope - Development/Community

# Development Option



AeroSuite 1.0.2.1

8203U February 22, 2024

**New Community/Development**

Development/ Community\*  
Aerobarrier Acres

Builder Name\*  
Aerobarrier Builders

ZipCode\* # 45342 City\* Miamisburg State\* Ohio Country\* USA

Email Mobile Number

**Model/Templates**

Model Name	Square Footage	Leakage Target
------------	----------------	----------------

**Attachments**

Logout

**Manage Sealing Events** **Add New Template** Save

OPTIONAL –  
Add new template  
OTHERWISE-  
Proceed to create seal event  
by “manage seal event”



# New Development Template



AeroSuite 1.0.2.1

**Edit Model/Template**

Model/Template Name\*  
Acres 1

Sq. Footage\* 1000    **Leakage Target\* 3**    Units ACH50

Avg. Ceiling Height (ft) 9    Struct. Volume (ft<sup>3</sup>)\* 9000    Construction Phase\* Post-DryWall

Number of Stories\* 1 on slab    Insulation Type\* Batt    Building Type\* Apartment

Notes

Close    Save

**PRO-TIP:**  
Whatever Target is entered here, will appear as an orange "target" line on the seal graph

In Aerosuite, you are able to create multiple templates for the development you are sealing. To create a template, input the details of one of the floorplans then click save.

# Creating a Seal Event



AeroSuite 1.0.2.1

8203U February 22, 2024

**New Community/Development**

Development/ Community\*  
Aerobarrier Acres

Builder Name\*  
Aerobarrier Builders

ZipCode\* # 45342

City\* Miamisburg

State\* Ohio

Country\* USA

Email

Mobile Number

**Model/Templates**

Model Name	Square Footage	Leakage Target
------------	----------------	----------------

**Attachments**

Logout

Manage **Manage Sealing Events** Template Save

Now that a template is created, the “manage sealing events” button should highlight. Click on that button to create a sealing event.

# Create Seal Event



AeroSuite 1.0.2.1

### New Envelope Sealing Event

Model/Template\*  Unit/Lot Number

Address\*

Sq. Footage\*  Leakage Target\*  Units

Avg. Ceiling Height (ft)  Struct. Volume (ft³)\*  Construction Phase\*

Number of Stories\*  Insulation Type\*  Building Type\*

Notes

Close Continue Sealing Save & New Save

**Development/ Community\***  
Aerobarrier Acres

**ZipCode\*** # 45342 **City\*** Miamisburg

**Model/Templates**

Model Name	Square Footage
Acres 1	1000

**Attachments**

Logout

Now that the templates are created, you can select the template to pre fill and the seal event will be set up information wise



# Pre-Prep Test



Pre-Prep Test with AeroSuite

AeroSuite 0.3.0.0

aeroseal. Preprep 9978 June 27, 2024

Preprep Preseal Seal Postseal Flush Depressurize Results

Builder Name: Aerobarrier Builders  
Address: 225 Byers Rd

00:00:00

Fan

0%

Automatic Manual

Ring Setting: no-ring

Target Pressure (Pa): 50

Fan Speed: 0%

0 Pa

Fan Pressure Fan Flow

Operational Leakage: (Calc.)

Preprep (Calc.)

Preseal

Postseal

Depressurize

Improvement

Logout

Next (F9)

**Would you like to conduct a Preprep Test?**  
Reminder: Preprep test is ran with a limited amount of Prep including: Plumbing Pipes (Supply Lines and Drains) and Exhaust Openings (Bath Fans, Dryer Vents, Range Hoods, ERV/HRVs)

No Yes

- Select a "Ring Setting" that matches the ring(s) installed on the fan inlet
- Click on "Start" button to run Leakage Test

# Pre-Prep Test



Pre-Prep Test with AeroSuite

AeroSuite 1.0.2.1

Preprep 8203U February 22, 2024

Preprep Preseal Seal Postseal Flush Depressurize Results

Builder Name: Aerobarrier Builders  
Address: 225 Byers Rd. 00:00:00

Ring Setting: Not Set Target Pressure (Pa): 50

Stop (F3) Start (F2)

Fan 0% Fan Speed Automatic Manual 0%

-0 Pa Envelope Pressure 0 Pa Fan Pressure - Fan Flow

- Select a "Ring Setting" that matches the ring(s) installed on the fan inlet
- Click on "Start" button to run Leakage Test

	CFM50	Sq. In.	ACH50
Operational Leakage (Calc.)	-	-	-
Preprep (Calc.)	-	-	-
Preseal	-	-	-
Postseal	-	-	-
Depressurize	-	-	-
Improvement	-	-	-

Logout Next (F9)

# Pre-Prep Test - RESULTS



AeroSuite 0.3.0.0

Preprep 9978 June 27, 2024

Preprep Preseal Seal Postseal Flush Depressurize Results

Builder Name: **Aerobarrier Builders**  
Address: **225 Byers Rd**  
00:00:46

Ring Setting: no-ring  
Target Pressure (Pa): 50

Stop(F3) Start(F2)

Fan  
0% Fan Speed  
Automatic Manual  
0 Pa Envelope Pressure | -0 Pa Fan Pressure | - Fan Flow

	CFM50	Sq.In.	ACH50
Operational Leakage: (Calc.)	-	-	-
Preprep	<b>703.4</b>	<b>84.7</b>	<b>1.88</b>
Preseal	-	-	-
Postseal	-	-	-
Depressurize	-	-	-
Improvement	-	-	-

- Preprep leakage test is completed. Re-running test will overwrite the existing values.
- If you wish to run test again, select a "Ring Setting" matching the ring(s) installed on the fan inlet
- Click on "Start" button to rerun Preprep leakage test

Logout Next (F9)

# PreSeal Test – Operational leakage Results (Calc)



AeroSuite 1.0.2.1

Preseal 8203U February 22, 2024

Preprep **Preseal** Seal Postseal Flush Depressurize Results

Builder Name: **Aerobarrier Builders** 00:00:30

Address: **225 Byers Rd.**

Ring Setting: no-ring Target Pressure (Pa): 50

Stop (F3) Start (F2)

Operational Leakage Units: - Enter Value: - Save

	CFM50	Sq. In.	ACH50
Operational Leakage (Calc.)	115.3	13.9	0.5
Preprep	556.9	67	2.5
Preseal	441.6	53.2	2
Postseal	-	-	-
Depressurize	-	-	-
Improvement	-	-	-

Fan 0% Fan Speed Automatic Manual

1 Pa Envelope Pressure 0.3 Pa Fan Pressure - Fan Flow

- Preseal leakage test is completed
- If you wish to run test again, select a "Ring Setting" matching the ring(s) installed on the fan inlet
- Click on "Start" button to rerun preseal leakage test

Previous (F8) Next (F9)

Once house is fully Prepped, Perform the Preseal test to calculate the operational leakage of the envelope

# Sealing Station Setup



A screenshot of the "Sealing Station Network" software interface. The top navigation bar shows the system ID "8203U", the date "February 22, 2024", and several icons: a refresh icon, a globe icon circled in red with a "2" notification, a bell icon with a "1" notification, a briefcase icon, and a help icon. Below the navigation bar, two sealing station cards are visible. The first card, "8203-A", is labeled "Ready To Seal" with a 100% battery indicator. It shows a "Sealant Level" dropdown set to "75%", a "Location" field containing "Master Bedroom", and a "Remaining Sealant" progress bar at 75%. Below these are fields for "Humidity: 29.2 % RH", "Temperature: 0 °F", "Sealant(Vol): 1.5 gal", and "Sealant(Time): 02:15:10". The second card, "8203-E", is also "Ready To Seal" with a 100% battery indicator. It shows a "Sealant Level" dropdown set to "100%", a "Location" field containing "Living Room", and a "Remaining Sealant" progress bar at 100%. Below these are fields for "Humidity: 29.8 % RH", "Temperature: 0 °F", "Sealant(Vol): 2 gal", and "Sealant(Time): 03:00:14".

After the Pre-seal test, set up the sealing stations in the software.

- Select the sprayer Icon in the top right of the screen and ensure you have your sealing stations on and connected.
- Select the sealant level and enter the location for each

## PRO-TIP

## TROUBLESHOOTING:

- Check Temps (Above 40F)
- Humidity (Below 90%RH)

See application Note: Cold Weather Operation in Appendix section



# Sealing Screen



AeroSuite 0.3.0.0

**aeroseal.** Sealing 9978 June 27, 2024

Preprep Preseal **Seal** Postseal Flush Depressurize Results

Builder Name: **Aerobarrier Builders** 00:00:00  
Address: **225 Byers Rd**

Ring Setting: **no-ring** Target Pressure (Pa): **200** Use Heater?: **-**

Pause(F4) Stop(F3) **Start(F2)**

Fan: 0% Fan Speed Automatic Manual 0%

-0 Pa Envelope Pressure | 0 Pa Fan Pressure | - Fan Flow

Heater:

**Envelope Leakage**

- CFM50 | - Sq.In. | - ACH50

Leakage @ CFM<sub>50</sub>

800  
600  
400  
200  
0

0 5 10 15 20 25

Op. Leakage Target

- Select "Ring Setting" & "Heater Selection"
- Click on [Start] or press [F2] to start sealing

**Seal Stations**

Stations ready to seal	2
Disabled stations	0
Stations injecting sealant	0
Stations pausing until RH reduced	0
Stations with issues	0
Estimated sealant injected(gal)	0

Inlet Humidity: **71.1%**  
Inlet Temp: **72 °F**  
Compressed Air: **87.3 PSI**

Logout E Stop (Esc) Previous (F8) Next (F9)

# Starting the Seal



AeroSuite 1.0.2.1

Sealing 8203U February 22, 2024

Preprep Preseal **Seal** Postseal Flush Depressurize Results

Builder Name: **Aerobarrier Builders**  
Address: **225 Byers Rd.** 00:00:24

Ring Setting: no-ring Target Pressure (Pa): 200 Use Heater?: Non-Electric

Pause (F4) Stop (F3) Start (F2)

Heater

Envelope Leakage: 474.8 CFM50 | 57.2 Sq.In. | 2.1 ACH50

Leakage @ CFM<sub>50</sub>

600 Target  
450  
300  
150  
0 Op. Leakage

0 5 10 15 20 25 30 35

Fan 52% Fan Speed Automatic Manual 0%

199.9 Pa Envelope Pressure 59.6 Pa Fan Pressure 885 CFM Fan Flow

System is currently sealing.

Seal Stations

Stations ready to seal	0
Disabled Stations	0
Stations injecting sealant	2
Stations pausing until RH reduced	0
Stations with issues	0
Estimated sealant injected(gal)	0

Inlet Humidity: 24.4%  
Inlet Temp: 73.8 °F  
Compressed Air: 107.3 PSI

Emergency Stop (Esc) Previous (F8) Next (F9)

Logout

# During the Seal



The Seal Graph can be enlarged if desired

# Sealing –TROUBLESHOOTING



The sealing cannot commence until compressed air pressure is at least 90PSI at the MCU. Make sure the trailer gauge is set to at minimum **100PSI** to achieve 90PSI at the MCU and manifold. If you do not get pressure, then it is either due to:

- Air leaks
- Water in compressor tank
- Leaks in incoming air hose or compressed air dryer assembly

Compressed Air must be > 85 PSI. Please check.

- If the graph starts to Flat-line, it could mean:
  - you are out of sealant
  - you have large penetrations that cannot be sealed
  - your sealant is not flowing out of the nozzles

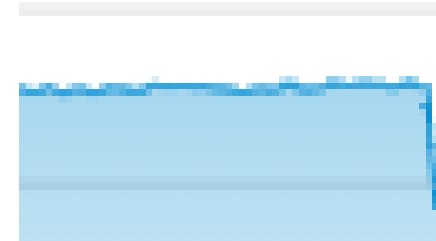

# Sealing-TROUBLESHOOTING



Sealing also cannot commence if the envelope pressure is below **10pa**. If you are unable to build 10pa of pressure on the envelope it could be due to:

- Ring setting too low
- Blue tube disconnected
- Huge leaks in the envelope

-0 Pa	0 Pa
Envelope Pressure	Fan Pressure

Be sure you know where to seal down to based on the operational leakage

	CFM50	Sq. In.	ACH50
Operational Leakage (Calc.)	115.3	13.9	0.5

Also check the notifications bell for any alarms/issues





# Changing Rings



AeroSuite 1.0.2.1

Sealing 8203U February 22, 2024

Dashboard Projects Settings

Builder Name: **Aerobarrier Builders**  
Address: **225 Byers Rd.** 00:07:06

Ring Setting: no-ring Target Pressure (Pa): 200 Use Heater?: Non-Electric

Pause (F4) Stop (F3) Start (F2)

Fan 50% Fan Speed Automatic Manual 0%

200.1 Pa Envelope Pressure 10.9 Pa Fan Pressure 397.2 CFM Fan Flow

Heater

Envelope Leakage 276.6 CFM50 33.3 Sq.In. 1.2 ACH50

System is currently sealing. Please change the ring to 5-inch ring.

Leakage @ CFM<sub>50</sub>

Seal Stations

Stations ready to seal	0
Disabled Stations	0
Stations injecting sealant	2
Stations pausing until RH reduced	0
Stations with issues	0
Estimated sealant injected(gal)	0.16

Inlet Humidity: 24.5%  
Inlet Temp: 73.8 °F  
Compressed Air: 97.3 PSI

Emergency Stop (Esc) Previous (F8) Next (F9) Logout

# Stopping the Seal

AeroSuite 1.0.2.1

Sealing 8203U February 22, 2024

Preprep Preseal **Seal** Postseal Flush Depressurize Results

Builder Name: **Aerobarrier Builders** 00:19:46  
Address: **225 Byers Rd.**

Ring Setting: 5-inch ring Target Pressure (Pa): 200 Use Heater?: Non-Electric

Pause (F4) **Stop (F3)** Start (F2)

Fan: 67% Fan Speed Automatic Manual 0%

199.8 Pa Envelope Pressure 334.5 Pa Fan Pressure 436.2 CFM Fan Flow

Envelope Leakage: 292.5 CFM50 | 35.2 Sq.In. | 1.3 ACH50

Sealing is STOPPED.

**PRO-TIP:**  
**ONCE SEAL IS COMPLETE**  
**HEATERS MUST BE TURNED OFF AT THIS TIME**

Seal Stations:  
Stations ready to seal: 2  
Disabled Stations: 0  
Stations injecting sealant: 0  
Stations pausing until RH reduced: 0  
Stations with issues: 0  
Estimated sealant injected(gal): 0.46

Inlet Humidity: 24.7%  
Inlet Temp: 73.8 °F  
Compressed Air: 106.2 PSI

Emergency Stop (Esc) Previous (F8) Next (F9)

# Post Seal



AeroSuite 1.0.2.1

Postseal 8203U February 23, 2024

Preprep Preseal Seal **Postseal** Flush Depressurize Results

Builder Name: Aerobarrier Builders  
Address: 225 Byers Rd. 00:00:00

Ring Setting: - Target Pressure (Pa): 50

Stop (F3) Start (F2)

Fan 0% Fan Speed Automatic Manual 0%

0 Pa Envelope Pressure 0 Pa Fan Pressure - Fan Flow

	CFM50	Sq. In.	ACH50
Operational Leakage (Calc.)	115.3	13.9	0.5
Preprep	556.9	67	2.5
Preseal	441.6	53.2	2
Postseal	210.2	25.3	0.9
Depressurize	-	-	-
Improvement	231.4	27.9	1

Logout Previous (F8) Next (F9)

# Flush



AeroSuite 0.3.0.0



Flushing

9978

June 27, 2024

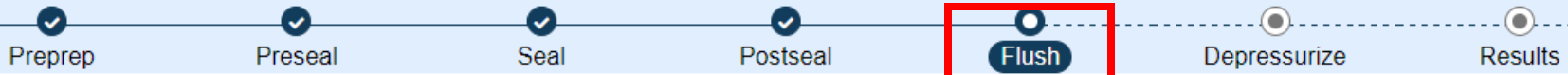

Builder Name: **Aerobarrier Builders**

Address:

00:00:00

Flushing Time  
1 min

Stop(F3)

Start(F2)

Fan

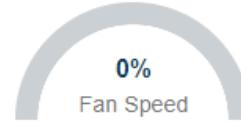

Automatic

Manual



0 %

0 Pa

Envelope Pressure

-0 Pa

Fan Pressure

### Seal Stations

Stations ready to seal	2
Disabled stations	0
Stations injecting sealant	0
Stations pausing until RH reduced	0
Stations with issues	0
Estimated sealant injected(gal)	0

Select a flush duration and click [Start] to begin flushing the seal station lines.

Logout

Previous (F8)

Next (F9)

# Depressurize



AeroSuite 1.0.2.1

Depressurize 8203U February 22, 2024

Preprep Preseal Seal Postseal Flush **Depressurize** Results

Builder Name: **Aerobarrier Builders**  
Address: **225 Byers Rd.** 00:00:01

Ring Setting: 5-inch ring Target Pressure (Pa): 50

Stop (F3) Start (F2)

Fan 0% Fan Speed Automatic Manual 0%

0 Pa Envelope Pressure 0 Pa Fan Pressure - Fan Flow

	CFM50	Sq. In.	ACH50
Operational Leakage (Calc.)	115.3	13.9	0.5
Preprep	556.9	67	2.5
Preseal	441.6	53.2	2
Postseal	210.2	25.3	0.9
Depressurize	-	-	-
Improvement	231.4	27.9	1

Optionally, you can depressurize the envelope like an actual blower door test to confirm the leakage in the envelope with only the pre-prep its masked (plumbing and drains)

Previous (F8) Next (F9)

Logout



# Depressurization Test Out

This is the most accurate representation of what a 3<sup>rd</sup> party Rater/Verifier is going to test.

1. Move the Fan and MCU inside – blowing out
2. Move blue tube to the outside
3. Remove all prep, except for plumbing fittings
4. Run the depressurized post-seal test

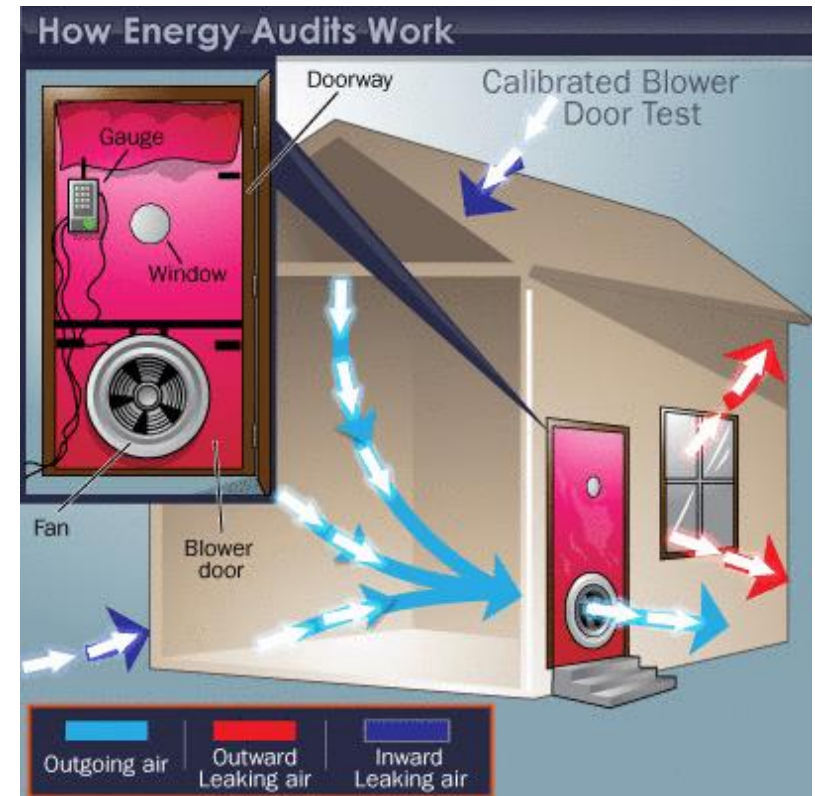

# Seal Report



AeroSuite 0.3.0.0

Certificate 9978 June 27, 2024

Preprep Preseal Seal Postseal Flush Depressurize Results

## SEAL REPORT

Envelope sealing performed for:  
Aerobarrier Builders  
1, 225 Byers Rd  
Miamisburg, OH 45342  
Phone:

Date: 6/27/2024  
Square Footage: 2500 ft<sup>2</sup>  
Structure Volume: 22500 ft<sup>3</sup>  
Operational Leakage: 100.0 CFM50

Leakage (CFM<sub>50</sub>)

Air changes per hour (ACH)

Metric	Before	After
Air changes per hour (ACH)	2.4 ACH50	0.9 ACH50
Leakage equivalent to	108.4 sq.in. hole	42.4 sq.in. hole

Leakage (CFM<sub>50</sub>) graph: 900.20

68.5% 00.12

Report Options: Seal Report

Language: English (United States)

Previous (F8)

Select Report  
Option of choice

**PRO-TIP:**  
Once you "Print certificate" you will not be able to go back and do more sealing

# Seal Report



## SEAL REPORT

**Envelope sealing performed for:**  
 Builder 1  
 Miamisburg, OH 45342  
 Phone:

Date: 2/2/2024  
 Square Footage: 1200 ft<sup>2</sup>  
 Structure Volume: 9600 ft<sup>3</sup>

**Leakage (CFM<sub>50</sub>)**

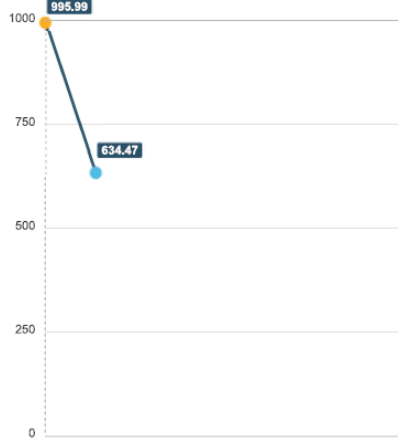

**Air changes per hour (ACH)**

6.2  
ACH50
4.0  
ACH50

**Leakage equivalent to**

119.9  
sq.in. hole
76.4  
sq.in. hole

**45.1%**  
Reduction in  
Envelope  
Leakage

**00:05**  
hh:mm  
Seal Time

● Before ● After

Note: Envelope leakage and air-change results are calculated at a STANDARD OPERATING PRESSURE of 50 Pa.

**Envelope sealing performed by:**  
 Aeroseal Developer  
 225 Byers Rd  
 Miamisburg, OH 45342  
 Phone: (123) 457 8900

Aeroseal Case ID:  
Hardware:

Scan for more details



Aeroseal  
aeroseal.com  
877-999-9999  
info@aeroseal.com



# Seal Report with Depressurization



## SEAL REPORT

**Envelope sealing performed for:**  
 Builder 1  
 Miamisburg, OH 45342  
 Phone:

Date: 2/2/2024  
 Square Footage: 1200 ft<sup>2</sup>  
 Structure Volume: 9600 ft<sup>3</sup>

**Leakage (CFM<sub>50</sub>)**

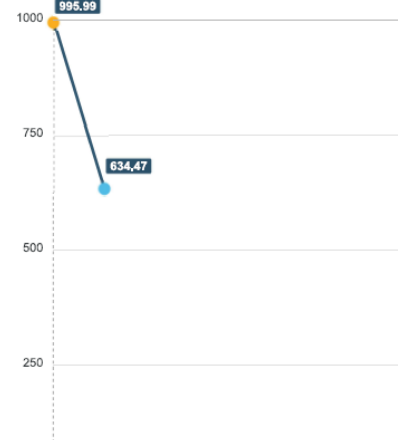

**Air changes per hour (ACH)**

6.2  
ACH50
4.0  
ACH50

**Leakage equivalent to**

119.9  
sq.in. hole
76.4  
sq.in. hole

**Depressurization Results**

3.8  
ACH50
72.4  
sq.in. hole

**45.1%**  
Reduction in  
Envelope  
Leakage

**00:05**  
hh:mm  
Seal Time

● Before ● After

Note: Envelope leakage and air-change results are calculated at a STANDARD OPERATING PRESSURE of 50 Pa.

**Envelope sealing performed by:**  
 Aeroseal Developer  
 225 Byers Rd  
 Miamisburg, OH 45342  
 Phone: (123) 457 8900

Aeroseal Case ID:  
Hardware:

Scan for more details



Aeroseal  
aeroseal.com  
877-999-9999  
info@aeroseal.com



Section 6

| MAINTENANCE

# General Maintenance



Part	How often to clean	How to clean	Tips
Nozzles	Every seal	Flush with water – use warm water if available	Whenever there is sealant build-up on the nozzles, soak in Buckeye cleaner. Disassemble as needed to clean sealant build-up.
Tubing	Every seal	Flush with water – use warm water if available	Remember to clear lines of water with compressed air after flushing
Connectors	Whenever build-up is observed	Connectors will not require cleaning as long as CLEAN tubing is inserted. Also, be sure to insert tubing all the way into the connector so it is fully seated.	Make sure tubing is clean every time you insert into connectors. This reduces the chance for leakage and air bubbles in the system.



Link to-Compressed Air system Maintenance video



Link to-Nozzle cleaning Video



Link to-Sealing station Maintenance Video



# Flushing the System



One of the key steps after you do the sealing job is to make sure that your liquid lines are free of sealant

- ALWAYS flush the system with CLEAN water. Use the purge switch and warm water if available.
- Make sure all tubing ends are clean before storage and before use.
- During cleanup, it is critical to do a manual flush to clear the sealant line

# Nozzle Cleaning

- When Cleaning the nozzle, it is recommended that the nozzles be soaked overnight in buckeye workout cleaner.
- The Nozzle contains 4 parts
  - 1.Nozzle head
  - 2.Liquid tube
  - 3.Ferrule
  - 4.Compression fitting

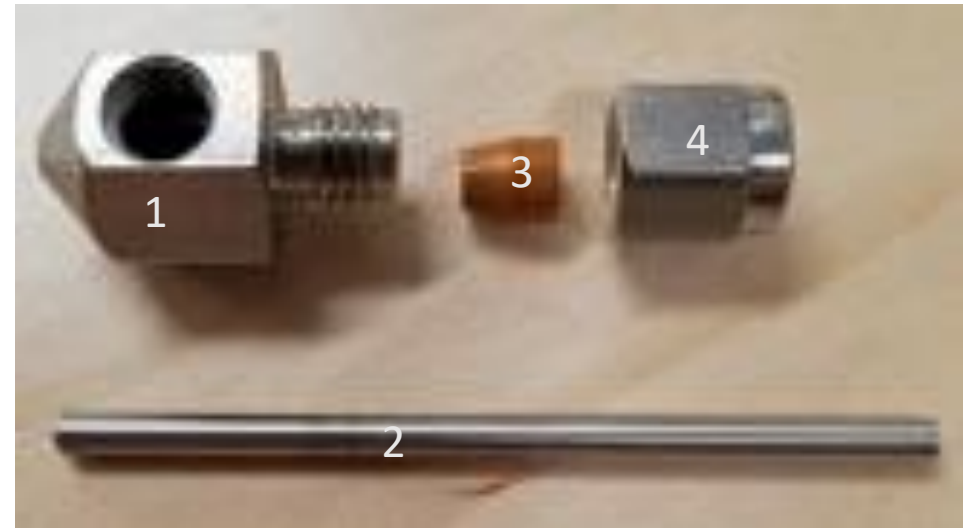

# Nozzle Cleaning Cont'd

- Make sure both the nozzle and liquid tube are completely clear of sealant.
- The compression fitting and ferrule just need to be dried.
- Check the air inserts for any sealant. Give the PTCs a quick cleaning



Brush inside the nozzle bore (both ends), female thread, and inside the central cavity



Ram rod for the interior of the insert



# Nozzle Reassembly

- To reassemble the nozzle, first put the ferrule **Curved side up** into the compression fitting
- Attach the compression fitting to the nozzle head and run the liquid tube (**Tapered end**) through
- Tighten with a wrench to ensure ferrule creates an airtight seal around the liquid tube
- **Important note: Ensure that the tapered end of the liquid tube is flush with the nozzle head to ensure efficient aerosolization.**

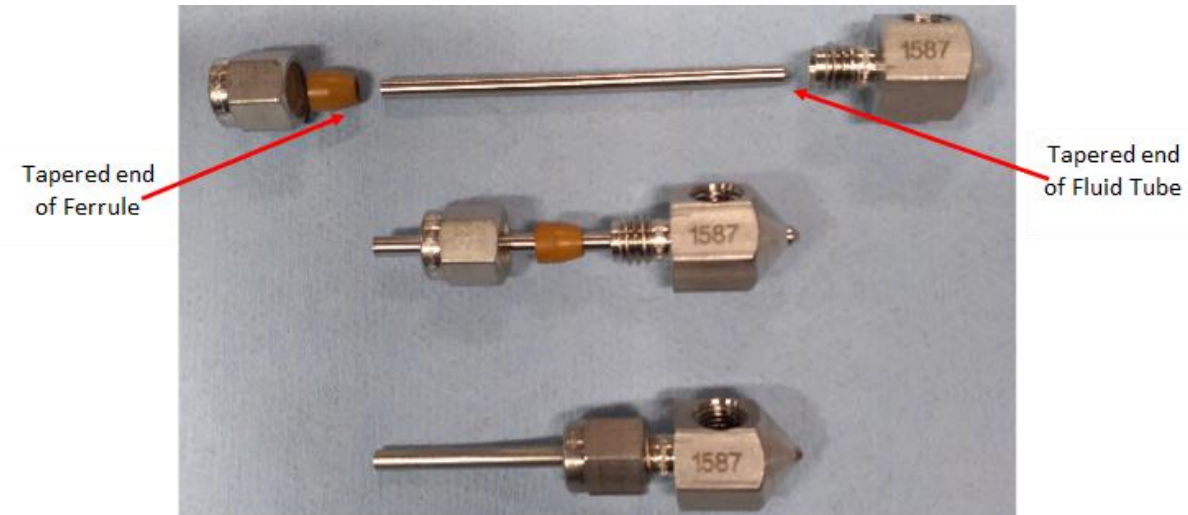

# Maintenance: Nozzle Cleaning

## Tip

- It is imperative that the nozzles are cleaned at the end of each day. Failure to clean the nozzles can lead to:
  - Sealant not fully aerosolizing, leading to the sealant falling to the floor in liquid form
  - No saturation of sealant in the envelope, causing longer seal times
  - Low compressed air flow, leading to no aerosolization in the sealant

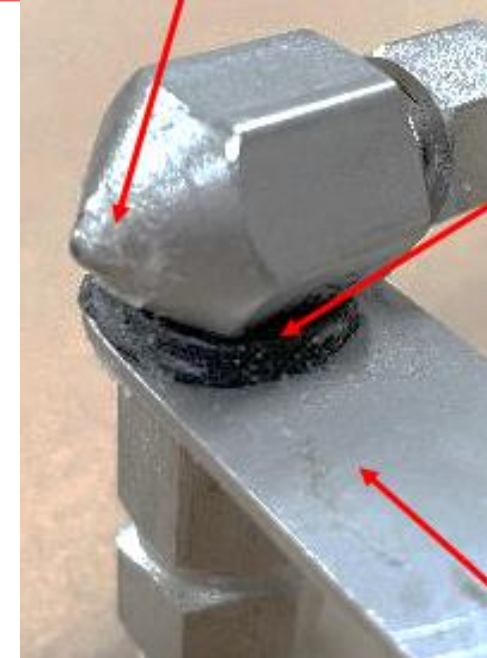



Section 7  
| APPENDIX

# APPENDIX



## GENERAL INFORMATION:

- TECHNICAL SUPPORT INFO PAGE
- ENVELOPE SEAL JOB CHECKLIST
- HOUSE PREP CHECKLIST
- ABS – S.O.P. CHECKLIST
- PRACTICE SEAL CHECKLIST

## APPLICATION NOTES:

- 001 – COLD WEATHER OPERATIONS
- 002 – POOLING SEALANT
- 003 – NOZZLE CLEANING DETAIL & LEAK TESTING

## ADDITIONAL DOCUMENTS:

- TRAILER –FULLY OUTFITTED
- OPTIONAL ACCESSORY PACKAGES

## VIDEO LIBRARY:

- QR CODE LINKS TO SHORT-SUBJECT TUTORIAL VIDEOS

# Aeroseal Envelope Contact Information



***Tech Support: (800)-772-6459 or (937)-428-9300  
ext.308***

*(If calling past 5pm est, leave a voicemail for the on-call tech to reach you)*

***Orders: (937)-428-9300 ext. 406***

***John Parkinson Cell: (937)-307-6228***





**ENVELOPE SEAL  
JOB CHECKLIST**

JOB NAME: \_\_\_\_\_

DATE: \_\_\_\_\_

- 1. ARRIVE AT JOBSITE – COMPLETE WALK-THRU TO DETERMINE PREP NECESSARY
- 2. SET UP: BLOWER DOOR / EQUIPMENT @ INJECTION POINT
- 3. AEROSUITE SOFTWARE – DATA ENTRY; JOB INFORMATION
- 4. PERFORM PRE-PREP OF HOUSE – AND PRE-PREP LEAKAGE TEST
- 5. FULL PREP OF HOUSE – AND PRE-SEAL LEAKAGE TEST
- 6. DETERMINE NUMBER AND LOCATION OF SEAL STATIONS – IDENTIFY AND CONNECT IN THE SOFTWARE
- 7. STIR SEALANT AND FILL SEAL STATIONS – SEALANT JUG AND WATER/FLUSH JUG
- 8. ENSURE (NEH) NON-ELECTRIC HEATER STATION HAS FUEL AND IS STARTED
- 9. BEGIN SEAL – TROUBLESHOOT DURING, FOR ANY CONDITIONS THAT NEED ATTENTION
- 10. AS SOON AS THE SEAL IS STOPPED – TURN OFF HEATER
- 11. PERFORM POST-SEAL LEAKAGE TEST
- 12. PERFORM FLUSH OF SEAL STATIONS
- 13. \* OPTIONAL – DEPRESSURIZATION TEST
- 14. VIEW/PRINT/SAVE SEAL REPORT
- 15. EQUIPMENT AND NOZZLE MAINTENANCE

PLEASE ALSO REFER TO THE "OPERATIONS MANUAL" FOR DETAILS



Prep work to be done in Building Envelope (before sealing step)

The main objective of prep work is to ensure there are no holes larger than 1/2" size and to protect any finished surfaces fixtures and gadgets in the home. Use painters tape, duct mask, foam guns and plastic sheets for this purpose. Ensure prep blower door test is complete before prepping

Address / Apartment# \_\_\_\_\_

Look for

How to Prep?

- Big holes
  - Manually block, use foam spray or use Duct Mask to temporarily seal
  - Check for plumbing penetrations (bathroom/kitchen sink/kitchen)
  - Block or spray foam any holes larger than 1/2" - plumbing holes, bottom sill plate etc.
- Vents
  - Duct mask tape or foam blocks on HVAC registers. Leave Boot Leakage Exposed
  - Duct Mask tape over range hood and dryer vents
  - Duct mask tape on bath fans
  - Let AB sealing process address the boot leakage (if any)*
  - Optionally use caulk to seal the boot leakage
- Windows
  - Check windows (close tightly) and inspect vent holes (tape them)
  - Cover the whole window using tape & drape plastic and painters tape
  - Cover window weep holes
- Doors
  - Exposed penetrations to be taped (painters tape or duct mask)
  - Be careful of sliding doors/tracks (cover with painters tape)
  - Protect horizontal surfaces, handles, knobs
  - Use painters tape to tape the seams between door and door frame
- Finished surfaces
  - Plastic sheets on counter tops/ bathroom ceramic fittings (all horizontal surfaces)
  - Cover plumbing fixtures - faucets, tubs, tiles
  - Kitchen cabinets-Tape the doors/drawers handles (using painters tape). Leave doors open.
  - Protect any finished flooring
- Electrical
  - Tape electrical outlet face (if installed).
  - Tape up main electrical panel (Do not let sealant go onto high voltage terminals)
  - Break drywall mud off of the outlet boxes
- HVAC equipment
  - Cover up the HVAC unit
  - Ensure all cabinet penetrations are covered
- ERVs
  - Duct Mask over the outer shell of the ERVs
  - Look for piping between HVAC and ERV and block the holes
- Light fittings & Fans
  - Preferably remove the fixtures to expose holes on wall/ ceiling
  - Cover up any wall mounted light fixtures.
  - Cover fans using plastic sheets (expose the mounting bracket/ ceiling for sealing)
  - Canned Lights - no additional prep; if you see sealant deposits then escalate to builder
- Fireplace
  - Cover fireplace completely (including vent holes) and tape up with Duct-Mask
  - \*Be careful of paint
  - Look for any other ventilation in the drywall framing into the fireplace
- Fire Suppression heads
  - Use the sprinkler cover plate to prep fire suppression heads

Tip: A good way to make sure no major gaps are left or hidden would be to use a smoke puffer

- 1) Install the Blower door and fan during Preseal
  - 2) Ramp up the fan manually and pressurize the room (ensure you are inside the room)
  - 3) Use smoke puffer to see the direction where smoke travels (smoke will exit out towards holes/leaks)
- Common locations - near cabinet edges, plumbing entries, electrical fixtures and panels

## Standard Operating Procedure for Aerobarrier Select System



### Pre Prep Blower Door Test and Envelope Preparation

- Set up the Machine for Pre Prep Test**
  - \_\_\_ Before Pulling Equipment, Ensure all exterior doors/windows are closed and locked
  - \_\_\_ Get MCU, Fan Assembly, And Blower Door and place at Injection point
  - \_\_\_ Set up Blower Door Frame by attaching the four frame pieces together
  - \_\_\_ Size Blower Door frame into Injection point door(either front door or garage door)
  - \_\_\_ Take Blower Door frame out of injection point and attach blower door canvas
  - \_\_\_ Put Blower Door back in place, attach crossbars and lock cam levers into place
  - \_\_\_ Connect Fan Pressure Tube (red) to fan+control Box
  - \_\_\_ Connect Envelope Pressure Tube (blue) to Fan assembly and run tube through Blower Door to the middle of the Envelope
  - \_\_\_ Connect Layflat tubing to Fan assembly+21" injection collar
  - \_\_\_ Place 21" Injection Collar to Blower door and attach Velcro on crossbar to rubber band on 21" Injection Collar
  - \_\_\_ Run 2 120v power legs and plug it into MCU+fan control box
  - \_\_\_ Turn on Generator
  - \_\_\_ Ensure Blue LED on MCU and Green Fan LED's light up when power is added
  - \_\_\_ Open up Aerosuite software and Run the pre prep Blower Door test (see Aerosuite checklist)
  - \_\_\_ Once test is complete, shut off generator
- Prep House and plan equipment layout**
  - \_\_\_ Prep the Envelope for Sealing (See Prep Checklist)
  - \_\_\_ Determine work space location outside of Envelope (i.e. in Garage, outside main door)
  - \_\_\_ Determine access door for entry during the seal (back door, front door, or blower door)
  - \_\_\_ Run 100ft Compressed Air hose from trailer to MCU
  - Sealing Station Layout**
    - \_\_\_ Typically Use one seal station per 500 sqft
    - Prep Sealant by mixing it with a paint mixer until solids at the bottom are mixed in.**

### **Standard Operating Procedure for Aerobarrier Select System**

#### Setting up Seal Stations, nozzles and compressed air manifold

- Set up Seal Stations**
  - \_\_\_ Place Seal Stations in areas you have designated for the seal
  - \_\_\_ Attach monopod to seal station
  - \_\_\_ Attach Nozzle Bracket to monopod
  - \_\_\_ Point nozzles away from walls and windows (allow 8ft of open space for the nozzles to spray)
  - \_\_\_ Connect liquid Tube to seal station connector on the right side of seal station
    - \_\_\_ Repeat the steps for each seal station
  - Priming the Seal Stations**
    - \_\_\_ Fill the two Gallon Jug with sealant and the Half Gallon jug with water
    - \_\_\_ Connect the water pump to the water Jug
    - \_\_\_ Connect the sealant pump to the sealant jug
    - \_\_\_ Power on Seal Station by pressing the red button (button should light up when on)
    - \_\_\_ Ensure all liquid tubes are connected to the seal station
    - \_\_\_ Hold down the black button to start the Priming process (let go of silver button when pumps start)
    - \_\_\_ Observe sealant from inside the sealing station until it gets to the "y" piece on the nozzle bracket.

- Hook up all Compressed Air hoses**

- \_\_\_ Connect 30ft Compressed Air Hose to MCU+Compressed air manifold
- \_\_\_ Place Compressed Air Manifold in a central part of the house where it reaches all seal Stations
- \_\_\_ Ensure unused ports are blocked using either jumper tubes or blocker pieces (both found in Spare Parts Kit). Recommend to cover up the manifold after properly hooking up all tube to avoid any clean effort needed after the job.
- \_\_\_ Connect Dual Bonded Tubing to the manifold
  - \_\_\_ Ensure dual bonded tubes are firmly connected to the manifold (feel for the sharkbite)
  - \_\_\_ Run dual bonded tubes to seal stations and connect to nozzle brackets (bottom part of bracket)
  - \_\_\_ Ensure dual bonded tubes are firmly connected to the nozzles (feel for the sharkbite)

#### Sealing Event

- Final Walkthrough before start of the seal**

- \_\_\_ Check Prep of the envelope to ensure areas needing protection are prepped
- \_\_\_ Ensure all sealing stations are powered on and primed
- \_\_\_ Ensure Sealing stations, manifold and hose reels are covered with protective materials
- \_\_\_ Ensure Envelope pressure tube (blue tube) is centrally located in the envelope

- Setting Up Blower Door for Seal**

- \_\_\_ Cut a piece of grid foam the width and length of the Injection door frame
- \_\_\_ In the foam, cut a 1in canal to allow for clearance of the 30" compressed air hose to run under Blower Door
- \_\_\_ put Blower Door back into Injection point, adjusting as necessary and lock cam levers into place
- \_\_\_ Place 21" sleeve back into the blower door, and reattach Velcro to rubber band

- Starting the Seal**

- \_\_\_ Start the Generator
- \_\_\_ Do the pre seal test (see Aerosuite Checklist)
- \_\_\_ Start the compressor on the trailer (ensure it has at least 100PSI on the trailer gauge)
- \_\_\_ Power on the NEH (if Using)
- \_\_\_ Put Fan Switch in the "ON" position
- \_\_\_ Click 'Start' button in Smartseal software to start the sealing step (see Smartseal software Checklist)
- \_\_\_ Ensure all LED's light up
- \_\_\_ Ensure fan spoils up to the set target pressure



## Standard Operating Procedure for Aerobarrier Select System

### Monitoring the seal

- \_\_\_ Watch the computer to ensure seal is going as planned (See Aerosuite Checklist)
- \_\_\_ Do a walk around on the outside of the envelope to look for sealant overspray (if applicable)
  - Sealant overspray appears as thin white cloud
  - Ensure Areas prepped are holding in place
- \_\_\_ 15-20 minutes into the seal, enter envelope through access door
  - Pause the seal (See Aerosuite checklist)
  - Check "the fog" to ensure sealant is spraying properly
  - Ensure compressed air is at 90psi on manifold gauge
  - Fix any issues with the equipment (loose compressed air connections, liquid connections)
  - Ensure prep is holding up and fix any missed prep
  - Exit the envelope and continue the seal
- \_\_\_ Every 30 minutes after initial entry, enter envelope through access door
  - Pause the seal (See Aerosuite checklist)
  - Check "the fog" and move sealing stations as needed
  - Do manual sealing as needed (using sprayfoam/caulk)
  - Exit the envelope and continue the seal
- \_\_\_ Continue the seal until desired leakage is reached
- \_\_\_ Ensure you take into account your pre prep Blower Door Leakage

### Ending the Seal

- \_\_\_ Stop the seal and do the post test (see Aerosuite Checklist)
- \_\_\_ Once flush is complete, shut off compressor and drain compressed air tank
- \_\_\_ Flush the Seal Stations (see Aerosuite checklist)
- \_\_\_ Create your seal report (see Aerosuite checklist)

### Equipment Clean Up

#### Envelope Purge

- \_\_\_ Enter Envelope through access door
- \_\_\_ Open 2-3 Windows in the envelope
- \_\_\_ Exit the Envelope
- \_\_\_ The envelope will purge for 15-20 minutes

#### Seal Station Tear Down

- \_\_\_ Disconnect monopod and nozzle bracket from Seal Station
- \_\_\_ Disconnect nozzles from nozzle bracket and place nozzles in cleaning solution
- \_\_\_ Disconnect sealant line from Sealant Jug and connect the same tube to the water jug
- \_\_\_ Purge the sealant line by using the purge button on sealing station
- \_\_\_ Continue purging until line is free and clear of sealant
- \_\_\_ Disconnect sealant line and Purge the Seal Station Lines with air using the purge button
- \_\_\_ Place any leftover sealant back into the 5 gallon buckets

#### Cleanup and demobilization

- \_\_\_ Ensure all prep is down
- \_\_\_ Clean any overspray of sealant
- \_\_\_ Place equipment back in trailer
- \_\_\_ For maintenance - follow Maintenance checklist





## Setting up for a Practice Seal

### Setting the Machine up for a Practice Seal

- Set up the Machine**
  - \_\_\_ Get MCU, Fan Assembly, And Seal Stations
  - \_\_\_ On the fan assembly, attach 36" layflat tubing and tie off the other end
  - \_\_\_ On the layflat tubing, cut a small slit for the blue tube and a 4"x4" hole to simulate leakage
  - \_\_\_ Connect Fan Pressure Tube (red) to fan+control box
  - \_\_\_ Connect Envelope Pressure Tube (blue) to the slit in the layflat
  - \_\_\_ Plug the Fan into 120v power
  - \_\_\_ Run two 120v power cords from the generator to the MCU+Fan Assembly
  - \_\_\_ Turn on the generator
  - \_\_\_ Ensure Blue LED on MCU and Green Fan LED's on control box light up when power is added
  - \_\_\_ Open up Aerosuite software and Run the pre-seal test (see Aerosuite checklist)

### Setting up Seal Stations, nozzles and compressed air manifold

- Set up Seal Stations**
  - \_\_\_ Place Seal Stations near the MCU
  - \_\_\_ Attach monopod to seal station
  - \_\_\_ Attach Nozzle Bracket to monopod
  - \_\_\_ Connect liquid Tube to seal station connector on the right side of seal station
    - Repeat the steps for each seal station
- Hook up all Compressed Air hoses**
  - \_\_\_ Connect 30ft Compressed Air Hose to MCU+Compressed air manifold
  - \_\_\_ Place Compressed Air Manifold in a central part of the house where it reaches all seal Stations
    - Ensure unused ports are blocked using either jumper tubes or blocker pieces (both found in Spare Parts Kit). Recommend to cover up the manifold after properly hooking up all tube to avoid any clean effort needed after the job.
  - \_\_\_ Connect Dual Bonded Tubing to the manifold
    - Ensure dual bonded tubes are firmly connected to the manifold (feel for the sharkbite)
    - Run dual bonded tubes to seal stations and connect to nozzle brackets (bottom part of bracket)
    - Ensure dual bonded tubes are firmly connected to the nozzles (feel for the sharkbite)

## Setting up for a Practice Seal

### Sealing Event

- Starting the practice Seal**
  - \_\_\_ Start the Generator
  - \_\_\_ Do the pre seal test and start the seal (see Aerosuite Checklist)
  - \_\_\_ Start the compressor on the trailer (ensure it has at least 100PSI on the trailer gauge)
  - \_\_\_ Plug in the Cylinder Heaters to the 120v outlets on the MCU
  - \_\_\_ Put Fan Switch in the "ON" position
  - \_\_\_ Click 'Start' button in Smartseal software to start the sealing step (see Smartseal software Checklist)
  - \_\_\_ Ensure all LED's light up on the control box
  - \_\_\_ Ensure fan spools up to the target pressure you set

- Ending the Seal**

- \_\_\_ Stop the seal and go to the post test (see Aerosuite checklist)
- \_\_\_ Do the Post Seal test (see Smartseal checklist)
- \_\_\_ Do the flush of the seal stations and drain compressor once complete
- \_\_\_ Create your seal report (see Aerosuite checklist)

### Equipment Clean Up

- Seal Station Tear Down**
  - \_\_\_ Disconnect monopod and nozzle bracket from Seal Station
  - \_\_\_ Disconnect sealant line from Sealant Jug and connect the same tube to the water jug
- Cleanup and demobilization**
  - \_\_\_ Place equipment back in trailer



# Cold Weather

- If Envelope is not heated, heaters will be needed to warm the structure. (*see cold weather application note*)



# AeroBarrier Cold Weather Operation

## How to use seal and use optional equipment during cold weather

### Purpose:

This document describes the AeroBarrier seal process during cold weather. This information will cover how to handle the sealant and other equipment during seals in cold weather.

### Sealant:

- ALWAYS store sealant above 40°F (4°C) as the sealant is water-based and will freeze if stored in cold conditions.
- Best Practice is to store sealant in a temperature-controlled warehouse and take only the required # of buckets to the job site. Any partial containers to be put back into the warehouse at the end of the day. If sealant does freeze, do not use and contact Aerospaceal for further instructions.
- Mix sealant every hour during a seal operation to avoid any change in viscosity.

### Pre-Heating the Space to be Sealed:

For sealing in very cold situations, ensure that the space being sealed is at least 40F with the temperature increasing.

- Existing heat source (furnace, other installed heat source that do not add moisture or combustion exhaust to the envelope). Sites that have installed heating systems should leave their system on the night before the seal operation.
- Space heaters inside the envelope (electric or indirect propane with exhaust going outside the envelope)
  - \* Heaters must be removed before the seal operation begins.
- Pre-heat with indirect propane heaters outside using duct to force air into the envelope
  - Pre heat with the AeroBarrier system
    - Set-up the blower door and fan/heater equipment before prep. Power will be needed for the fan, and separate power will be needed for the heaters as there will be no power control from the MCU (Main Control Unit) before the seal operation is in progress. All of these will be running at 100% when plugged directly into 110V 20A power. Four outlets will be needed (3 heaters, 1 fan).
      - First, turn the fan on (plug-in). The fan must be in operation before power is applied to the heaters. The fan must remain on the entire time the heaters are energized and for five minutes after the heaters have been de-energized. Plug the heaters into the local power or generator. Once the fan/heater assembly is supplying heated air to the envelope, let it run while prep is completed.

### Prep the Space:

In cold conditions, tape adhesion may be reduced. You may need to clean some surfaces and remove dust/dirt to make sure tape stays in place during the seal operation.

### Pre-Heating Air During the Sealing Operation:

An indirect heater can be used to warm the air going into the blower door fan with the following directions:

- The exhaust from the heater must be routed outside the seal/work area. Direct fire propane heaters should not be used due to the moisture that will be added to the air.
- Air flow from the heater should not point directly into the blower door fan. This may cause incorrect CFM readings.

### Post Seal:

Remove condensation from the compressed air system

- drain the compressor
- close the valve
- restart the compressor
- blow out the air line to purge any condensation (Keep air hose from freezing by purging the air lines after use)
- drain the compressor
- if you do find hoses/tubing that have some frozen water, thaw that equipment inside a heated building. Use a hot air gun on low or a hair dryer and slowly thaw the frozen section of the hose or tubing.
- ALWAYS ensure that the hose reels and machine are free of water before storing away after the job.
- After the Flush step of your AeroBarrier process (when you pump water through the liquid lines and nozzle), remember to blow the hose reels out using the compressed air. Removing moisture from the lines will eliminate any wait time for the equipment to thaw out before your next job.

The best option: store the equipment and hose reels in conditioned environment above 40 degrees F



Tips:

- Be aware of uninsulated walls - as cold walls will cause condensation on the inside and will not retain heat.
- Plan on seal rates (pump injection rates) being slower than in summer months.
- If a long section of hose reels is outside & exposed to elements, then consider routing them through insulated sleeves.

Using a tent for shelter. A larger tent can be used for to pre-heat air going into the blower door where the building design allows. Otherwise, use the garage area to pre-heat air and create a warm area to work. Always remember to keep exhaust outside and leave an opening for air flow for the blower door.



Indirect heater example

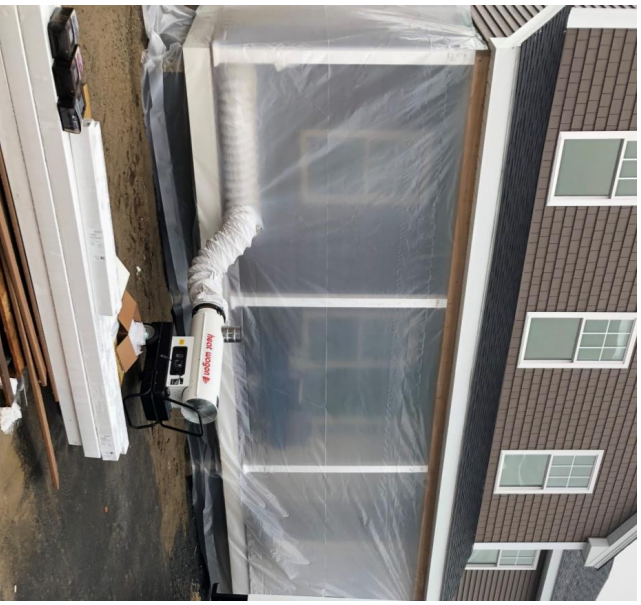
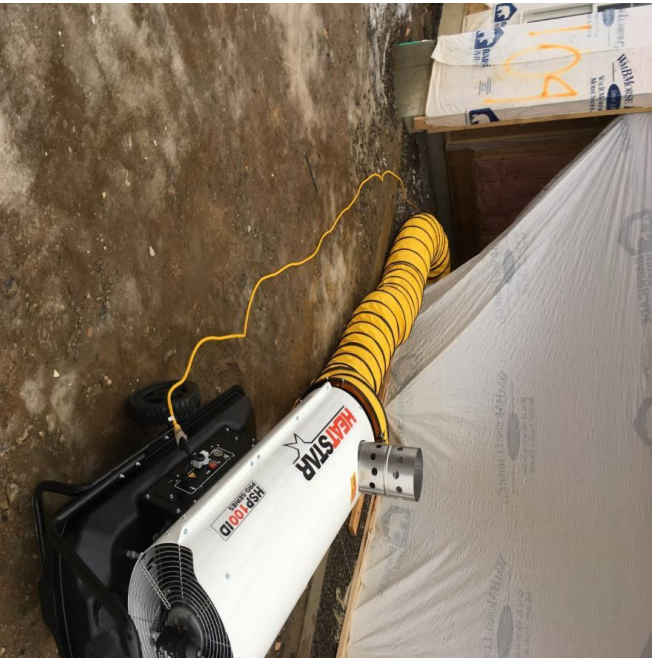



# Sealant Pooling Prevention and Resolution

## Component Setup and Cleaning

Sealant puddling in front of the sealing stations can be caused by two different factors, insufficient compressed air supply at the nozzle or the fluid tube position within the nozzle. Both can cause undesirable sealant droplet sizes, causing them to fall to the ground and create puddles of sealant. The following list provides guidance on what causes, and how to prevent, sealant puddles from forming

### Potential causes of sealant puddling (in order of likelihood):

- 1. Air Leaks: Nozzle Assembly and Compressed Air Manifold**
  - Leaks in the compressed air system (anywhere from compressor to nozzle body) reduce the pressure and air flow from the nozzle tip, where it's needed to create sealant droplets that can be suspended in air. Lower pressure and air flow at the nozzle tip will create larger droplets or even drips that fall out of the surrounding air and create puddles on the floor.
  - Critical Areas for a Correctly Functioning Nozzle (pg 2) provides more detail surrounding the nozzle.
  - Leaks at the compressed air manifold have the same effect as leaks at the nozzle assembly. Although less common than nozzle leaks, care must be taken to ensure the compressed air generated at the compressor reaches the nozzle tip where it is needed
  - Manifold Disassembly and Cleaning (pg 19) covers this component.
- 2. Contamination: Dirty Nozzle Bore and Tip**
  - Dirt particles and other build-up in the compressed air gap at the tip of the nozzle (between the nozzle bore and fluid tube) restrict the opening for the compressed air. Restrictions of any type, especially in this area, will also create larger sealant droplets that will puddle on the floor.
  - Nozzle Disassembly and Cleaning (pg 8) and Nozzle Reassembly and Inspection (pg 15) provide more detail on this issue.
- 3. Setup: Air pressure setting at compressor (100 psi recommended)**
  - Increasing the compressor setting to 100 psi will help ensure the pressure and air flow seen at the nozzle tip is sufficient for proper sealant droplet creation (even if very small leaks are present in the compressed air lines)
- 4. Setup: Fluid Tube Position within the Nozzle**
  - Correctly positioning the fluid tube within the nozzle tip helps create an ideal direction / path for the air flow to interact with the sealant stream. Visually aligning the parts during nozzle reassembly works well if you understand how the air is flowing and key features that need to align. Critical Areas for a Correctly Functioning Nozzle (pg 2) and Nozzle Reassembly and Inspection (pg 15) cover fluid tube alignment needs.
- 5. Air Leaks: Other locations.**
  - While the nozzle assembly and compressed air manifold are more common leak points, other fittings and even a cut air hose will cause air leaks. If leaks are suspected, the system can be tested with a spray bottle and soap water (pg 24)

### Critical Areas for a Properly Functioning Nozzle Assembly:

- A. Nozzle Tip
- B. Ferrule Seal
- C. O-Rings
- D. Push to Connect Fittings

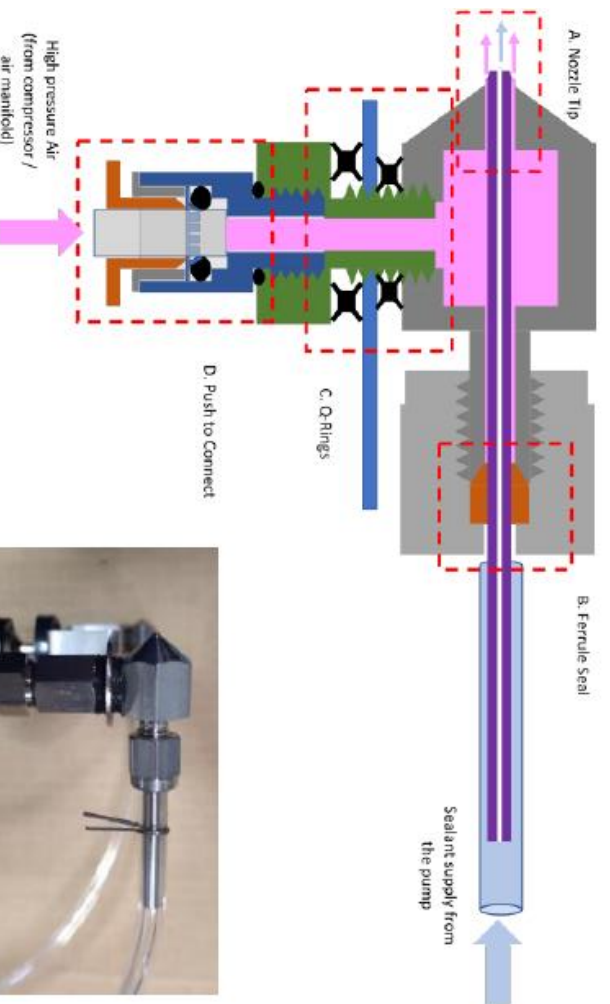

Side view of clean mounted nozzle



### A - Nozzle Tip: Sealant build-up reduces air flow

The compressed air gap between the fluid tube and the nozzle bore **MUST** be clean

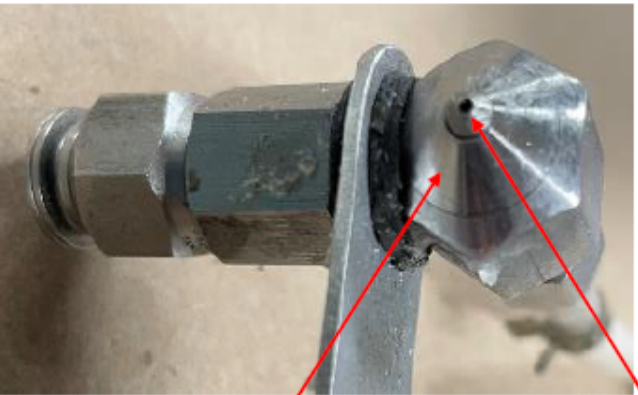

Functioning nozzle after a sealing

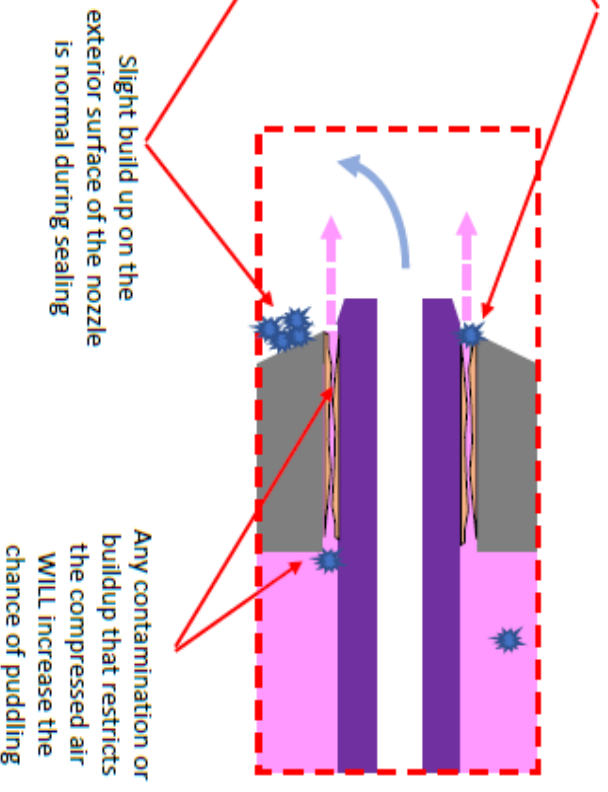

Slight build up on the exterior surface of the nozzle is normal during sealing

Any contamination or buildup that restricts the compressed air **WILL** increase the chance of puddling

### Nozzle Tip: Clean Surfaces

- A small amount of sealant buildup on the nozzle is normal and expected during a sealing job.
- This build up is typically on the outside of the nozzle, away from the compressed air flow path
- IF sealant or other contaminants get into the gap between the outside of the fluid tube and the inside bore of the nozzle, it **WILL** restrict airflow and increase the chance of sealant puddling in front of the nozzle

### A - Nozzle Tip: Fluid tube alignment sets the direction of the air flow

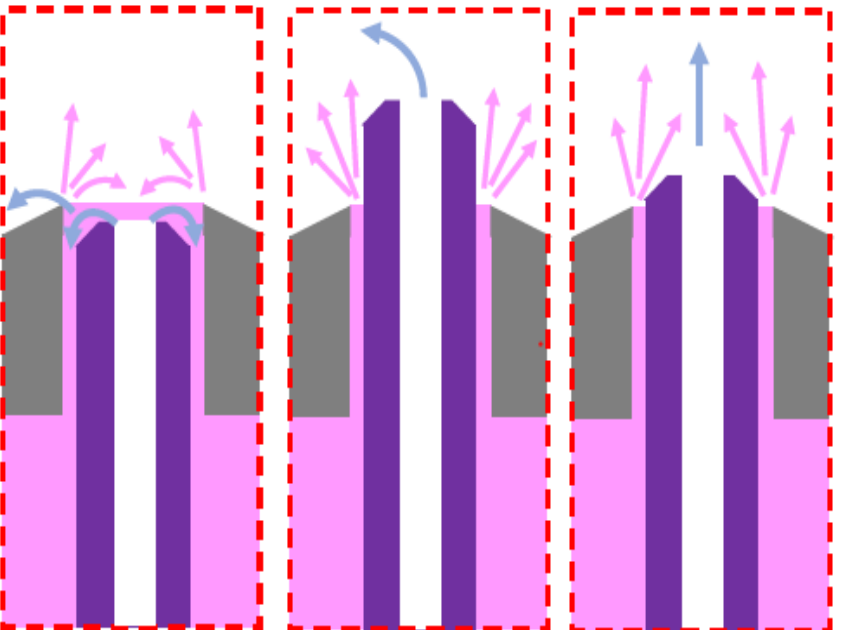

Correct Position – the transition point of the fluid tube is aligned with the tip of the nozzle

Fluid tube proud of the nozzle tip – compressed air is forced away from the fluid stream and the sealant will drip from the nozzle

Fluid tube recessed into the nozzle tip – Compressed air will force sealant back into the nozzle, creating blockage

### Nozzle Tip: Fluid Tube Alignment

- The fluid tube must be positioned so the transition point of the angled tip aligns with the end of the nozzle body
- IF the tube sticks out too far, the compressed air will blow away from the sealant stream – this will not break the stream into small droplets and the sealant will puddle
- IF the tube is recessed, the compressed air will force sealant back into the nozzle and create blockage. This blockage will build and restrict air flow.

## B. Ferrule Seal:

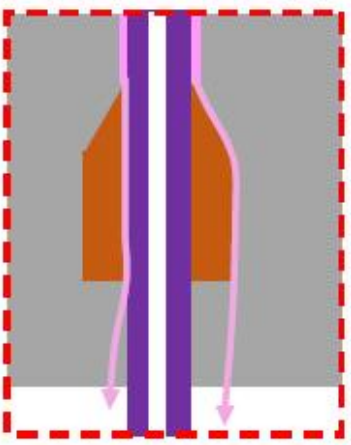

Functional Ferrule:  
smooth surfaces,  
clean edges



Leaking Ferrule: pitted  
and chipped surfaces  
(cleaned with harsh  
chemicals)



Leaking Ferrule: installed  
and tightened backward in  
the nozzle body



Leaking Ferrule: Sharp  
ridge at end of tapered  
surface, chipped  
leading edge (excessive  
compression from seal  
nut)

## Ferrule Seal:

- The ferrule seals the rear of the nozzle to the fluid tube
- Damage from over-tightening, chipped edges, or other surface damage can cause compressed air leaks (stealing air from the nozzle tip)

## C. Q-Rings



Functional Q-Ring  
(round, clean, all  
surfaces intact)



Damaged Q-Ring (Cut  
by twisting nozzle after  
assembly)



Damaged Q-Ring (distortion  
from over-compression and  
debris from incomplete  
cleaning)

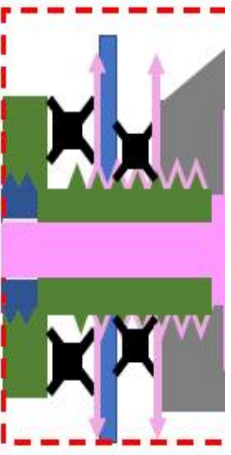

Leak caused sealant build  
up across the compressed  
air gap at the nozzle tip  
(puddling under the nozzle)

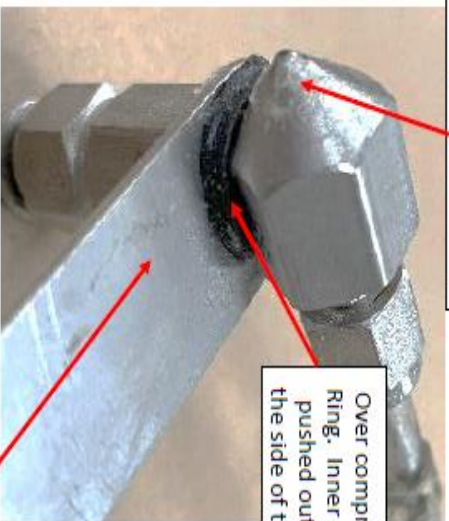

Over compressed Q-  
Ring. Inner diameter  
pushed out around  
the side of the nozzle

Visible spray pattern  
from leaking Q-Ring

## Q-Rings:

- Q-Rings are used to seal the PTC adapter and nozzle to the nozzle bracket
- The cross section of the Q-Ring has 4 round lobes (making concentric circles). The inner surface creates most of the seal.
- Cuts and debris on surfaces will create air leaks
- Overtightening the nozzle to the bracket will squeeze the Q-Ring out of position where the seal cannot be maintained causing air to leak around it.



## E. Push to Connect Fittings

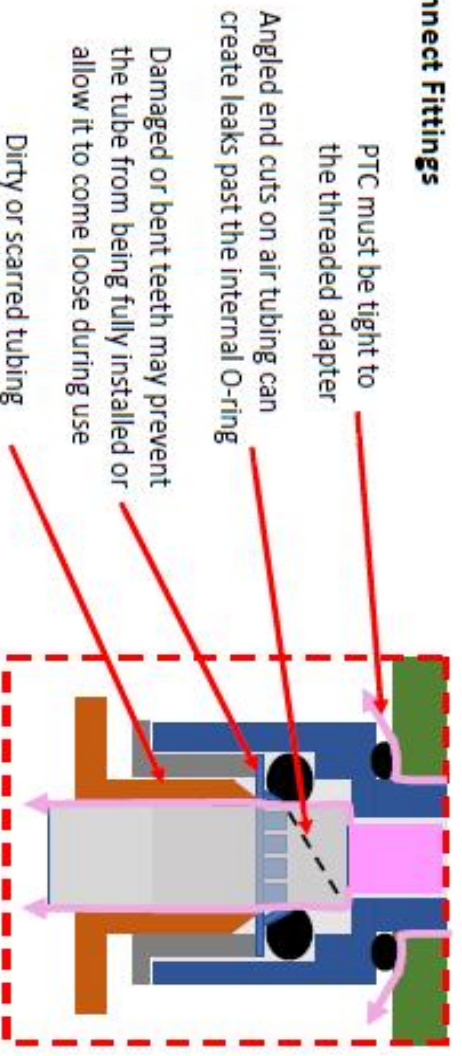

Damaged retention teeth



Gouged surfaces on the flexible tube  
(area inserted into the PTC)



Angled cut on  
tube end

## D. Push to Connect: Nozzle assembly and compressed air manifold

- The push to connect (PTC) both secures and seals the flexible compressed air tube to the bottom of the nozzle assembly
- There are 2 sealing surfaces on the part – both need to be clean and undamaged to prevent leaks:
  - O-ring on the exterior that seals to the threaded adapter
  - O-ring inside the PTC that seals to the flexible tube
- The PTC also has internal “teeth” that hold the flexible tube in position when its installed. The outer collar must be fully compressed to release the teeth before disassembly
  - The flexible tube end condition (last 3/4”) is also critical to creating a seal.
  - The tube surface must be clean and free from scratches
  - The cut end of the tube must be perpendicular to the length and free of any burrs
  - The tube must be fully installed past the teeth and O-ring



## Nozzle Cleaning - Detailed Instructions

Remove Flexible Tubing:

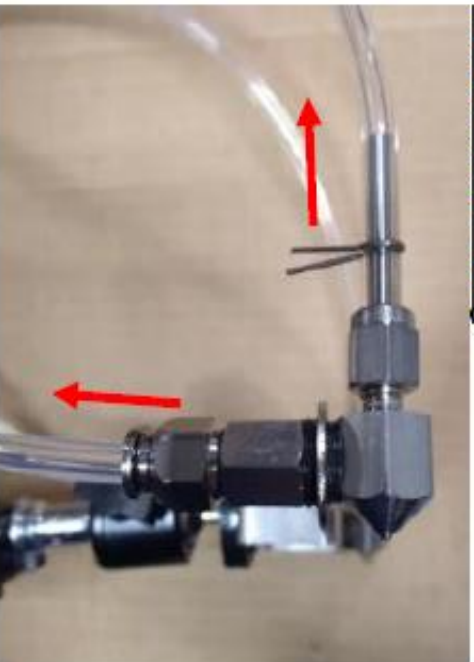

1. Slide clamps back and remove fluid tubing
2. Remove compressed air tubing from PTC

Disassemble Nozzle:

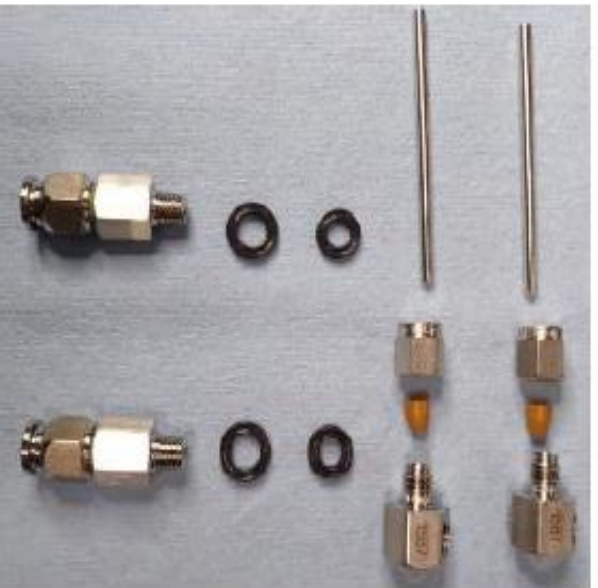

1. Unthread the PTC / Threaded adapter from the bottom of the bracket (hold the nozzle body stationary)
2. Remove the Q-Rings
3. Fully remove the seal nut
4. Separate the fluid tube, ferrule, and nozzle body

Inspect the Parts:

- Inspect for build-up and debris in nozzle ID and inside the body. This must be removed during cleaning.
- Inspect for damage on the Q-Rings. Replace the ring(s) if damaged.



Note: This is a severe case of build-up inside the nozzle, but ANY restriction in the inner diameter of the nozzle must be removed.



If any nicks, cuts, abrasions, or deformation are found on either Q-Ring, there WILL be a leak that impacts nozzle performance. Replace the ring with a new one (match the size) from the spare parts kit.



### Cleaning Soak:

- Soak all metal pieces in Buckeye Workout cleaner for a minimum of 5 minutes, do not dilute (agitate during soak).
- **WARNING:** Buckeye solvent has the potential for damaging the rubber seals if soaked for extended periods of time (i.e. overnight soaking). Soaking for 5 minutes is effective without the risk of damaging the parts.

### Cleaning Scrub:

- Clean ALL interior surfaces with small spiral brushes
- USING BRUSHES REDUCES THE CHANCE OF LEAVING DEBRIS / LINT INSIDE THE NOZZLE COMPONENTS
- Twisting the brush clockwise during insertion into the part can help pull debris to the outside edges where it can be more easily cleaned
- A dental pick is also useful for removing debris from the interior of parts
- Use the ram rod for reaming the ID of the fluid tube
- Wipe the exterior surfaces with shop towels



Brush inside the nozzle bore (both ends), female thread, and inside the central cavity of the part



Brush the interior of the air inlet fittings (both ends)



Ram rod for the interior of the insert tube

### Rinse:

2-minute rinse in hot water (agitate during soak)

### Dry Parts:

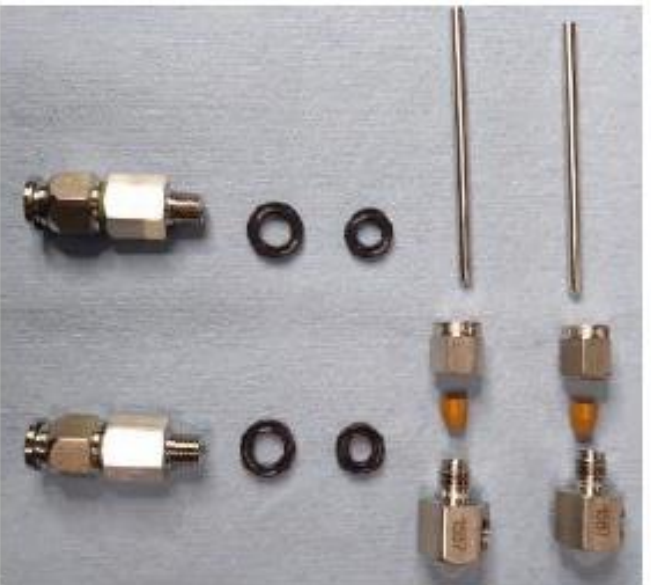

- Blow dry (inside and outside) with filtered compressed air
- IF ANY SURFACE IS STILL TACKY OR HAS SMEARED SEALANT, REPEAT THE CLEANING PROCESS WITH FRESH SOLVENT AND WATER RINSE



### Inspect Nozzle Body

- The ID bore at the tip must be bright steel. Any build-up or film can restrict compressed air flow.
- The internal ferrule must be clean and free of any contamination that can break free and block the compressed air gap from the inside of the nozzle.
- The ferrule mating surface must also be clean and free of contamination

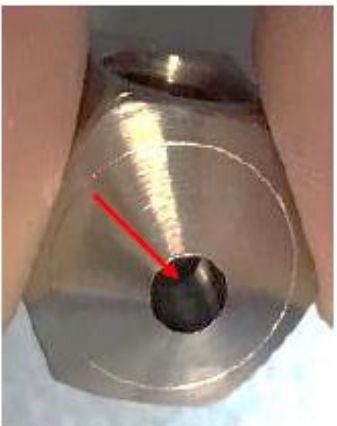

**Nozzle Tip:** No build-up or debris in the tip ID, central cavity, or taper at the back of the part

**NOTE:** Even small particles can restrict airflow enough to cause issues



### Inspect Nozzle Body

- Fluid Tube – no debris, sealant build-up / film, or damage. The first 1/2" from the tapered end is critical (mates with the nozzle bore to create the compressed air path)



**Fluid Tube:** No debris on the ID, outside is bright steel – no build-up (if a fingernail catches on the surface, repeat cleaning) especially in the first 1/2" from the tapered end

### Inspect Ferrule

- The surface of the ferrule must be clean and smooth.
- Pitting, ridges, or scratches will cause air leaks



**Functional Ferrule:**  
smooth surfaces,  
clean edges



**Leaking Ferrule:** pitted and chipped surfaces (cleaned with harsh chemicals)



**Leaking Ferrule:** installed and tightened backward in the nozzle body



**Leaking Ferrule:** Sharp ridge at end of tapered surface, chipped leading edge (excessive compression from seal nut)

Inspect the Push to Connect Fittings

- The center bore must be free of debris
- The release collar must move freely with respect to the body (must fully compress to release the retention teeth)
- After cleaning with brushes and Buckeye Workout, it may still be difficult to determine if the internal parts of the PTC have residue on them. One suggestion is to use a clean piece of 1/4" tubing – install and remove the tubing and feel for any resistance on the tube (sticking to the internal O-ring or dragging on the retention teeth)



PTC  
Contamination  
on the O-ring



PTC Missing Retention Teeth  
(Tube pulled out without  
fully compressing collar)



Release collar  
must move freely  
(Fully press in and  
return on its own)

Assemble Nozzle

- Loosely assemble the nozzle body, fluid tube, ferrule, and seal nut
- ENSURE THE TAPERED END OF THE FERRULE MATES WITH THE BACK OF THE NOZZLE BODY
- ENSURE THE TAPERED END OF THE FLUID TUBE IS INSERTED INTO THE NOZZLE BODY

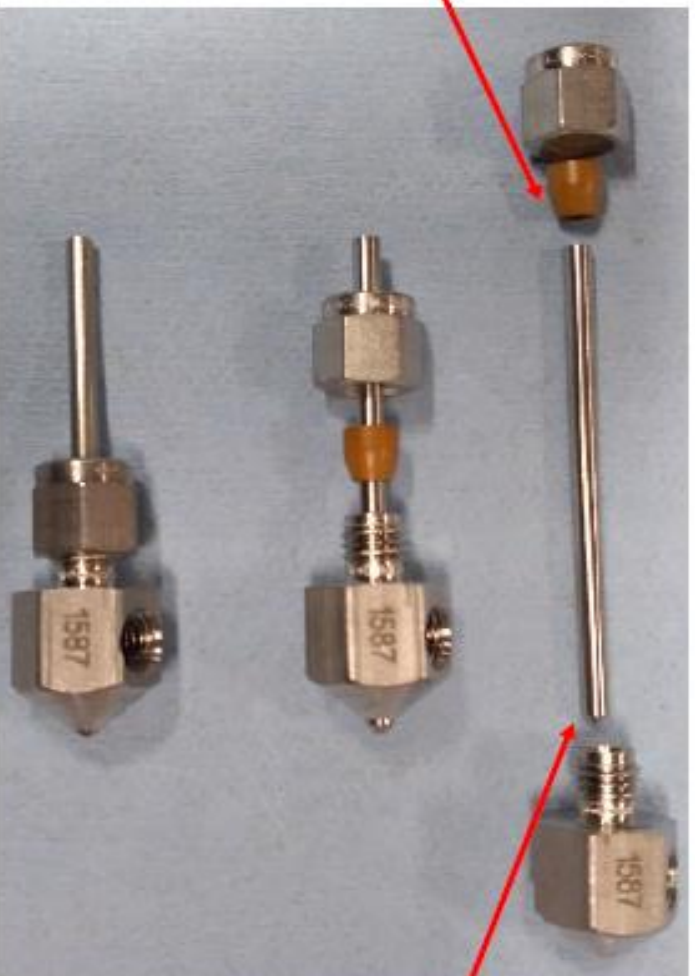

Tapered end  
of Ferrule

Tapered end  
of Fluid Tube





### Adjust the Fluid Tube Position

- The transition point between the tapered end and the full body diameter of the fluid tube must align with the tip of the nozzle body
- Secure the fluid tube position by tightening the seal nut (finger tight + 1/4 turn MAX)
- Verify the fluid tube remained in position after tightening the seal nut



Fluid Tube Transition Point (before adjustment)



Adjust Insert Tube stick-out so the taper matches the nozzle.



Tighten seal nut: finger tight + 1/4 turn MAX

### Assemble the Push to Connect and Q-Rings

- Install the large Q-Ring fully onto the threaded adapter (push flush to the shoulder on the fitting)
- The small Q-Ring on top of the nozzle bracket (push flush to the bracket)

When assembled correctly, there should be appx 2 threads showing at the top of the threaded adapter

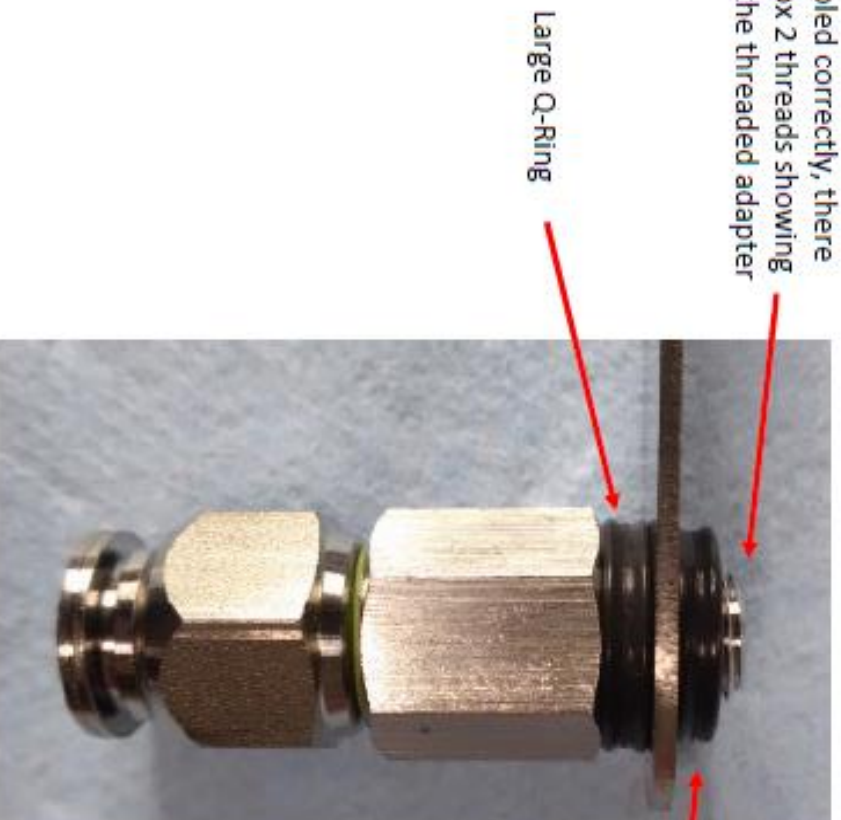

Large Q-Ring

Small Q-Ring

## Assemble Nozzle Body

- Hold the nozzle stationary and thread the PTC 2 full turns into it (turn the PTC, NOT the nozzle during assembly)
- There is a thin edge at the bottom of the nozzle that can cut the Q-Ring if the nozzle is twisted
- The nozzle assembly may not feel fully "tight" when correctly assembled. It should not rattle on the bracket, but over compressing the Q-Rings (3<sup>rd</sup> turn on the inlet elbow) will create leaks and cause issues with droplet formation
- NOTE: if the nozzle direction needs to be adjusted for setup on the job, loosen the PTC slightly prior to turning the nozzle body.

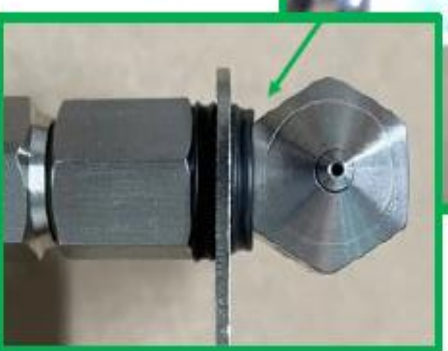
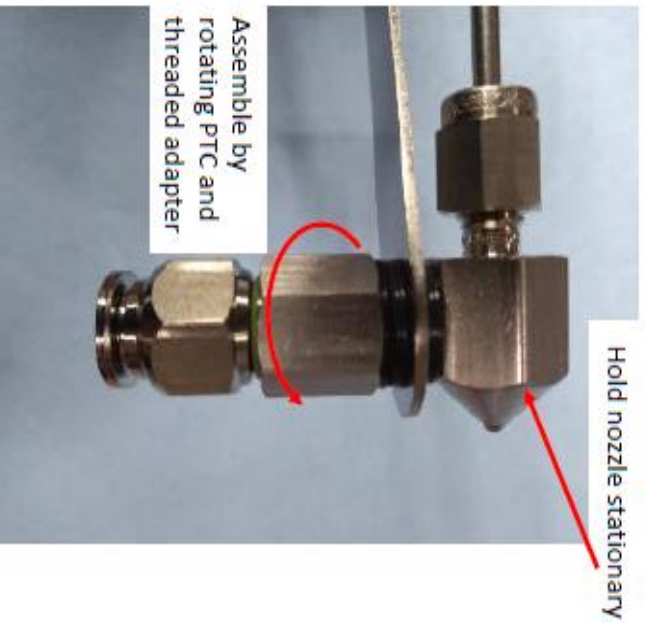

## Leak Testing

The entire compressed air path can be leak tested using a spray bottle of soap water. Bubbles will form at any leak (threaded fittings, tube ends, push to connects, etc.)





**Provide Your Own Vehicle of Choice**

**AeroBarrier Select  
Basic Equipment Package**

- 1 120V Fan
  - 1 Lo-Pro Main Control Unit
  - 1 Laptop Computer
  - 1 Non-Electric Heat
  - 1 Blower Door
  - 5 Sealing Stations
  - + Required Accessories
- +**
- Modular Air and Power Package**
- 1 Wheelbarrow Gasoline Compressor
  - 1 Honda Gasoline Generator

*If Needed Add*

**AeroBarrier Select  
Extra Capacity Add-On Package**

- +3 Sealing Stations
- +1 Wheelbarrow Gasoline Compressor

**aerobarrier**  
SELECT

**or**

**Purchase with a Built Out Trailer**

**AeroBarrier Select  
Basic Equipment Package**

- 1 120V Fan
  - 1 Lo-Pro Main Control Unit
  - 1 Laptop Computer
  - 1 Non-Electric Heat
  - 1 Blower Door
  - 8 Sealing Stations
  - + Required Accessories
- + Your choice of trailer option with  
air & power package below

**+**

**Trailer Option with  
Air & Power Package**

(Must Select One)

**Standard Trailer Option**

- 1 Trailer with Build Out
- Modular Air and Power Package**
- 2 Wheelbarrow Gasoline Compressors
  - 1 Honda Gasoline Generator

**or**

**Diesel Trailer Option**

- 1 Trailer with Build Out
- Diesel Air and Power Package**
- 1 Diesel Compressor/Generator

**aeroseal**  
ENVELOPE



[aeroseal.com/aerobarrier](http://aeroseal.com/aerobarrier)

Aeroseal LLC | (937) 428-9300 | [info@aerobarrier.net](mailto:info@aerobarrier.net)



# ADDITIONAL TROUBLESHOOTING VIDEO TUTORIALS



Checking the Seal Station Battery



Why is One Nozzle Spraying?



Basic Building Science Terminology